

# Drones, Droids and Robots

$$x = \frac{-b \pm \sqrt{b^2 - 4ac}}{2a}$$

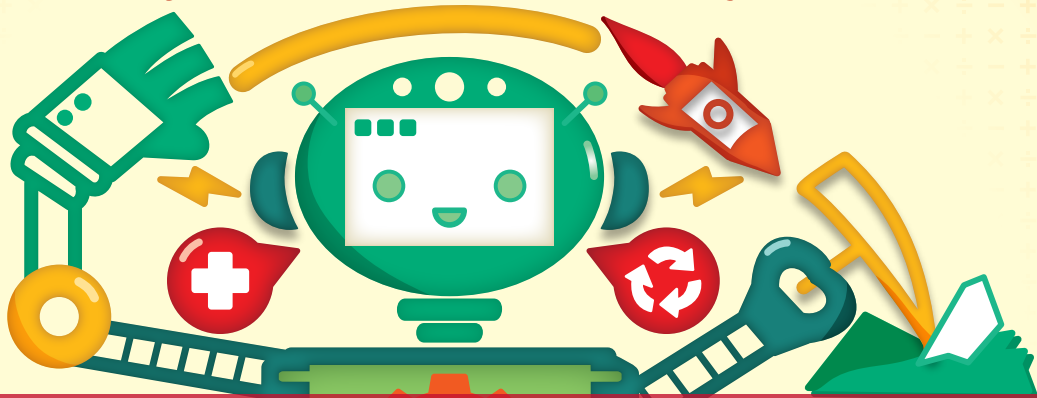

A resource book of ideas for  
National Science Week 2016

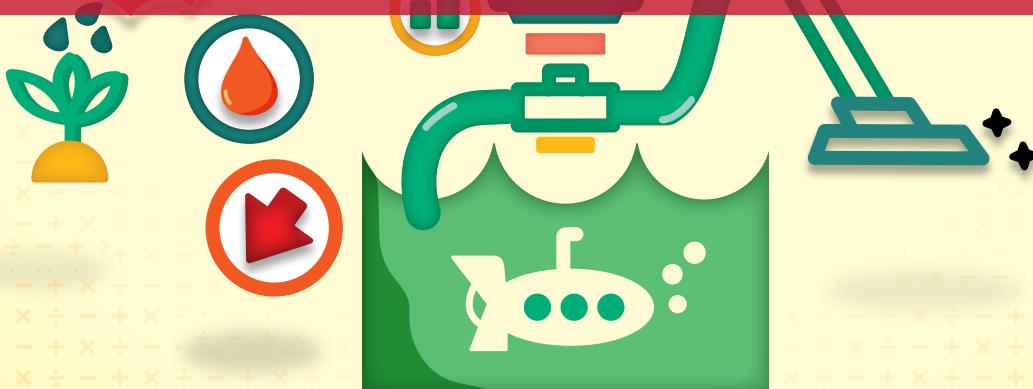

 national science week 2016

[www.scienceweek.net.au](http://www.scienceweek.net.au)  
13-21 August

  
An Australian Government Initiative

  
Inspiring  
AUSTRALIA



# ASSIST

AUSTRALIAN SCHOOL SCIENCE  
INFORMATION SUPPORT FOR  
TEACHERS AND TECHNICIANS

# CONNECTED LEARNING EXPERIENCE (CLE)

## A NEW RESOURCE FOR TEACHERS OF SCIENCE (F-10)

A  
CLE is a **teaching package** that combines all the elements necessary to maximise student learning through a **single hands-on practical experience** or **series of tasks**.

CLEs are comprehensive resources providing teacher background information, teaching and learning plans, digital resources such as video clips and interactive simulations, student workbooks and support for assessment of student learning outcomes.

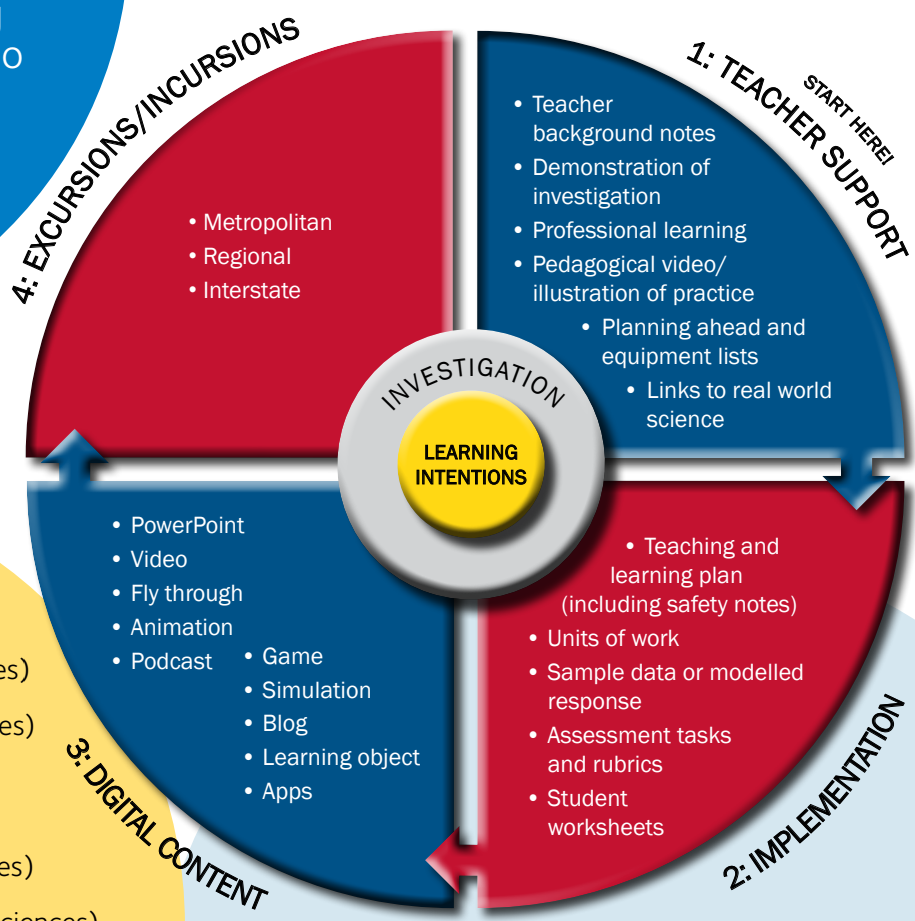

- ### Currently available on the Science ASSIST website:
- **Sound and hearing** (Year 1 Physical sciences)
  - **The penguin project** (Year 3 Physical sciences)
    - **Magnetism and electrostatics** (Year 4 Physical sciences)
  - **Biodiversity study** (Year 6 Biological sciences)
  - **Dark side of the moon** (Year 7 Earth and space sciences)
  - **Investigating patterns of inheritance** (Year 10 Biological sciences)
    - **Reaction rates** (Year 10 Chemical sciences)
  - **Expansion of the universe** (Year 10 Earth and space sciences)
    - **The egg bungee jump** (Year 10 Physical sciences)

For more information and access to these free resources go to:  
**assist.asta.edu.au. Search for 'CLE'**



AUSTRALIAN  
SCIENCE  
TEACHERS  
ASSOCIATION



# DRONES, DROIDS AND ROBOTS

## Table of contents

<i>President's Message</i> .....	3
<i>Foreword</i> .....	4
<i>Introduction</i> .....	5
<b>1: From science fiction to science fact</b> .....	6
<b>2: Drones, droids and robots — What's the difference?</b> .....	12
<b>3: Interactive fun — Learning in disguise!</b> .....	19
<b>4: How do we use drones, droids and robots?</b> .....	22
<b>What's doing with drones?</b> .....	22
<b>Robot round up</b> .....	32
<b>Making life easier with robots</b> .....	42
<b>Robots into the future</b> .....	49
<b>5: Exploring some of the science</b> .....	54
<b>Communicating remotely</b> .....	54
<b>Flight</b> .....	57
<b>Circuits</b> .....	58
<b>Materials used in construction</b> .....	60
<b>Powering drones, droids and robots</b> .....	62
<b>6: Maths makes it happen!</b> .....	68
<b>7: Robotics competitions for schools</b> .....	70
<b>8: Snapshots of what's happening in schools</b> .....	73

## Acknowledgements

Authors: Deb Smith, Jane Wright, Steve Zander, Shelley Murphy, Sue Monteath, Anna Davis, Deborah Lee

Many thanks to the universities and schools that provided information on their robotics programs.

Design and layout: Marcus Viskich, Hot Chocolate Productions; Zoë Murphy, Gent-Murphy Design.

Publisher: Australian Science Teachers Association PO Box 334, DEAKIN WEST ACT 2600

## President's Message

*Drones, Droids and Robots* is the school theme for National Science Week 2016. It was chosen specifically to highlight STEM—Science, Technology, Engineering and Maths—by focusing on autonomous systems technology. This is an engaging theme for teachers and their students to explore, as the field of research is diverse, innovative and fast-paced. What's more, it takes us on a fascinating journey between 'science fiction' and 'science fact'.

Whilst *Drones, Droids and Robots* has been developed to support teachers to do theme-related activities during National Science Week 13-21 August 2016, the information, activities, weblinks and Australian research case studies will continue to be a valuable addition to any teacher's set of STEM resources.

The Australian Science Teachers Association is pleased to provide this web-based digital book free of charge to all educators, thanks to the ongoing funding support from the Australian Government through the *Inspiring Australia* initiative.

I'd like to encourage all teachers of science across Australia to use *Drones, Droids and Robots* to promote STEM to their students

Anne Disney,  
ASTA President

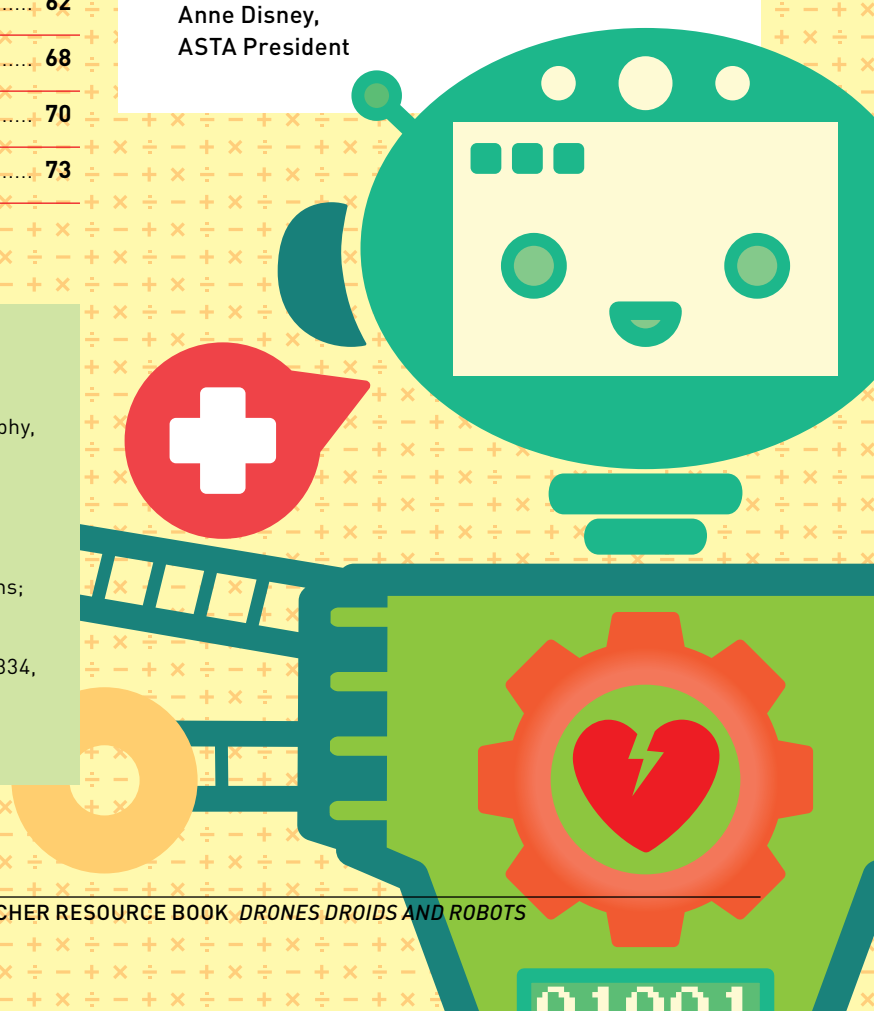

## FOREWORD BY MARITA CHENG

I feel like I've come a long way from being a schoolgirl in Cairns in far north Queensland ten years ago.

I've studied computing and mechanical engineering at the University of Melbourne and Imperial College in London, and artificial intelligence and robotics at Singularity University in California, which teaches us to use exponential technologies to impact the lives of a billion people within the next 10 years.

When I was at university I noticed that there weren't that many girls studying engineering with me, so I founded Robogals, organising volunteers to visit schools with robots to encourage girls to stick with maths, science and technology. I've left Robogals now, but it's still running in nine countries and I'm very proud of the program.

As the 2012 Young Australian of the Year (and National Science Week Ambassador!) I got to meet and speak to thousands of people including about 10,000 schoolgirls, encouraging them to study engineering.

And now I spend my days being a robotics engineer, developing a telepresence robot that will have uses in business, health, aged care, schools and even in homes. It will go to market later this year and will be available ready-to-use, as well as in a kit for students to build themselves and then program in class.

My personal goal is to bring robots to the world and our day to day lives, and have them impact billions of people in a positive way.

Enjoy learning about, building and programming some *drones, droids and robots* with your students for National Science Week this year and into the future. We need many more STEM graduates and I might be needing to employ some of them soon!

**Marita Cheng**

Entrepreneur and Robotics Engineer  
Founder, 2Mar Robotics



## INTRODUCTION

### A STEM adventure — Drones, droids and robots

We have long been fascinated by the robots and androids depicted in science fiction books and films—BB-8 being the latest—and with the idea that one day we will have robots to do the housework and other mundane chores. Drones have long been used in the military, but to most of us drones are the ‘quad-copters’ of various sizes that are becoming increasingly accessible as a ‘tech toys’. They are certainly fun to play with! However, drones, droids and robots come in many shapes and sizes with infinite uses and their significance in solving our current and future challenges cannot be overstated.

The aim of the 2016 National Science Week resource book *Drones, Droids and Robots* is to provide educators and their students a glimpse into the **real**, fast-paced world of autonomous technology research and devices. It is designed to showcase the close links between the disciplines of Science, Technology, Engineering and Maths at a time when there is a strong move to restore the focus and increase the uptake of STEM subjects in schools. It also highlights the most innovative research that is taking place with the application of autonomous technologies in agriculture, mining, manufacture, conservation, education...and many more.

This book is in no way intending to be an exhaustive look at this technology. Rather it is a series of ‘snapshots’ on:

- the ‘sci-fiction to sci-fact’ history and definition of drones, droids and robots
- the way drones, droids and robots are used today
- some of the science and maths behind the development and use of this technology
- ‘cutting edge’ research and innovation, with case studies from some Australian universities
- learning opportunities for schools.

Included are links to articles, videos, activities, interactives for younger students, images and further information. It has been designed to allow teachers to delve in and out depending their interests and the interests of their students. There are opportunities to link to all aspects of STEM.

Links to particular areas of the curriculum—science, mathematics, design technology and digital technology are made in various chapters to assist teachers to identify STEM opportunities. Chapter 6 also provides links to specific content descriptors in the mathematics curriculum.



An Australian Government Initiative



## CHAPTER 1: FROM SCIENCE FICTION TO SCIENCE FACT

### Back to the future

Our expectations of technology in the real world often come from science fiction content. From the imagination of writers such things as lasers, robots, rocket ships and atomic power were all described in science fiction long before they became science fact. Inspiration from science fiction has lead researchers and designers to develop novel devices and systems that change the ways we do things.

For example, it has been suggested that the 2002 movie [Minority Report](#) influenced the development of multi-touch interfaces such as those in smartphones and iPads. Many *Star Trek* technologies, such as personal access display devices and smart watches have actually been created in the 21st century. In the movie, [The Matrix](#) the main protagonist, Neo, demonstrated the ultimate interface with a computer where kung-fu skills were 'uploaded' into his brain. Brain scientists are developing a way of amplifying learning in a way that mimics the method used in *The Matrix*. (see ['Scientists develop Matrix-style technique of 'feeding' information directly into your brain'](#), 19 February 2016, The Mirror). For an accompanying video see ['Enhanced training through neurostimulation'](#), YouTube (5:06 min)

The era of self-driving machines, like K.I.T.T. (an advanced, artificially intelligent self-aware car) in the original 1982 [Knight Rider TV series](#), is already here. It is predicted that by 2040 four out of every ten vehicles on the road will be autonomous.

► [Replica of KITT](#) [Source: [Arrow](#), Wikimedia, [CC BY-SA 3.0](#)]

▼ [Junior, a robotic Volkswagen Passat at Stanford University in 2009](#) [Source: Steve Jurvetson, Wikimedia, [CC BY 2.0](#)]



If you want to learn more about comparisons between science fiction and science fact read the following article: ['Science fact vs fiction in Star Wars and other sci-fi movies: relax and enjoy the entertainment'](#).

*The Conversation*. 20 January 2016.

## What about robots?

Droids, drones and robots were initially the realm of science fiction writers. Ever since the first robot, Maria, took the form of the film's heroine in Fritz Lang's 1927 film [Metropolis](#), autonomous machines have gripped our imagination.

The idea of 'man-made intelligence' has a long history. It is seen in mythological characters such as Talos of Crete—a giant bronze automaton that protected the mother of King Minos of Crete, Golem—a magically animated, anthropomorphic character from Jewish folklore, and of course, Frankenstein's 'monster' made from the parts of dead men and animated via a lightning bolt. Most of the 'robots' we know today are not anthropomorphic and are quite unglamorous devices, like robotic welders and the autonomous vacuum cleaner (often called a 'robovac') and fall far short of the ones depicted in mythology, fiction and science fiction.

▼ ['Maria' from the Metropolis movie. Statue in Babelsberg, Germany.](#)  
 [Source: Havelbaude, Wikimedia, CC BY 3.0]



▲ [Winged 'TALON' armed with a stone. Silver didrachma from Phaistos, Crete \(ca. 300/280-270 BC\), obverse](#)  
 [Cabinet des Médailles, Paris].  
 (Source: Wikimedia, Public Domain)

Isaac Asimov, the famous science fiction writer, used the word 'robotics' to describe the technology of robots and predicted the rise of a powerful robot industry. In 1942 he wrote the incredible Robot series of short stories, which were included in his famous novel, *I, Robot*. The series centred on the idea of robots having 'positronic brains'; an artificial intelligence that enabled them to learn. Asimov was already considering the dangers of intelligent robots and so formulated the three laws of robotics to keep them in check.

**'First Law:** A robot may not injure a human being or, through inaction allow a human being to come to harm.

**Second Law:** A robot must obey orders given to it by human beings, except where such orders conflict with the first law.

**Third Law:** A robot must protect its own existence as long as such protection does not conflict with the first or second law.'

Many of the ideas described in Asimov's short stories were incorporated into the 2004 film, *I, Robot* starring Will Smith ([I, Robot, Official trailer](#), YouTube, 2:26 min), although the screenplay came mostly from an unrelated script titled *Hardwired* written by Jeff Vintar. Another of Asimov's short stories, *The Bicentennial Man*, was adapted into the 1999 movie [Bicentennial Man](#) ([Bicentennial Man – Official® Trailer](#), YouTube 2:49 min) starring the late Robin Williams.

Fictional robots have not always been benign. In many works of science fiction, like the movies *Transformers* and *Terminator*, while some of the robots acquire human capabilities and emotional connections to humans, other others are bent on the destruction of humanity. In the classic Stanley Kubrick movie, *2001: A Space Odyssey* released in 1968, the on-board computer HAL demonstrates emotion and begins to eliminate the crew to ensure its own survival. (Trailer, [2001: A Space Odyssey](#), IMDb 3:32 min)

Science fiction has often favoured characters that are anthropomorphic and indistinguishable from humans, such as those in the classic tech noir film [Blade Runner](#) ([Blade Runner \(1982\) Official Trailer](#), YouTube 3:37 min) and [Surrogates](#) ([Surrogates Official Trailer](#), YouTube 2:31 min). Movie directors take advantage of the human tendency to create bonds with human-like, fictional characters so their movies have the potential to do well at the box office.

A readers poll published in [COSMOS Magazine Issue 59 \(2014\) Beyond Sci-Fi](#), identified the readers top 10 fictional robots to be:

1. [Bender](#) — Futurama
2. [Marvin: The Paranoid Android](#) — Hitchhikers Guide to the Galaxy
3. [Data](#) — Star Trek
4. [R2D2](#) — Star Wars
5. [Sonny](#) — I, Robot
6. [Optimus Prime](#) — Transformers
7. [Class M-3 Model B9](#) — Lost in Space
8. [Johnny Five](#) — Short Circuit
9. [Wall-E](#) — Wall-E
10. [The Terminator](#) — Terminator

The top five classic science fiction novels chosen were:

1. [I, Robot](#) — Isaac Asimov (1950)
2. [Do Androids Dream of Electric Sheep](#) — Philip K. Dick (1968)
3. [R.U.R \(Rossum's Universal Robots\)](#) — Karel Capek (1920)
4. *The Humanoids* — Jack Williamson (1949)
5. [Cyborg](#) — Martin Caidin (1972)



▲ [I, Robot head](#) (Source: Shao19, Wikimedia [CC BY-SA 2.0](#))

▼ [Publicity photo of American character actor, Jonathan Harris with robot B-9](#) (Source Wikipedia, Public Domain)





As you read through the chapters: *What's doing with drones?*, *Robot round up*, *Making life easier with robots* and *Robots into the future* you will see how these machines are penetrating all walks of life, performing manual tasks and assisting in social contexts.

Smart robots are here. They can accomplish intelligent actions, make rational decisions, learn from experience and even make new robots. Johnny Five (from the movie [Short Circuit](#)) demonstrated knowledge acquisition...and scientists are currently building machines that can do just this. WOPR (War Operations Plan Response) computer in the movie [War Games](#) (1983) ([War Games Official Trailer](#), YouTube 2:19 min) demonstrated a machine learning by itself. This has been demonstrated in the real world by current computers such as:

- IBM's Watson. Find out about Watson by watching [IBM Watson: How it works](#) (YouTube 7:53 min) and how it played the game show, Jeopardy ([IBM's Watson Supercomputer destroys humans in Jeopardy](#), YouTube, 3:52 min)
- IBM's Deep Blue that outplayed the World Chess champion Garry Kasparov (watch [Deep Blue beat G. Kasparov in 1997](#), YouTube, 6:06 min)
- [Google Deep Mind AlphaGo](#) ([Go](#)) beat professional Go player Lee Se-dol in October 2015. (See Chapter 4.4 for more information.)

These three super computers all 'learnt' to play intelligent games and defeated world champions.

Humans can now build a machine that does their work so why not build a human or part of a human?

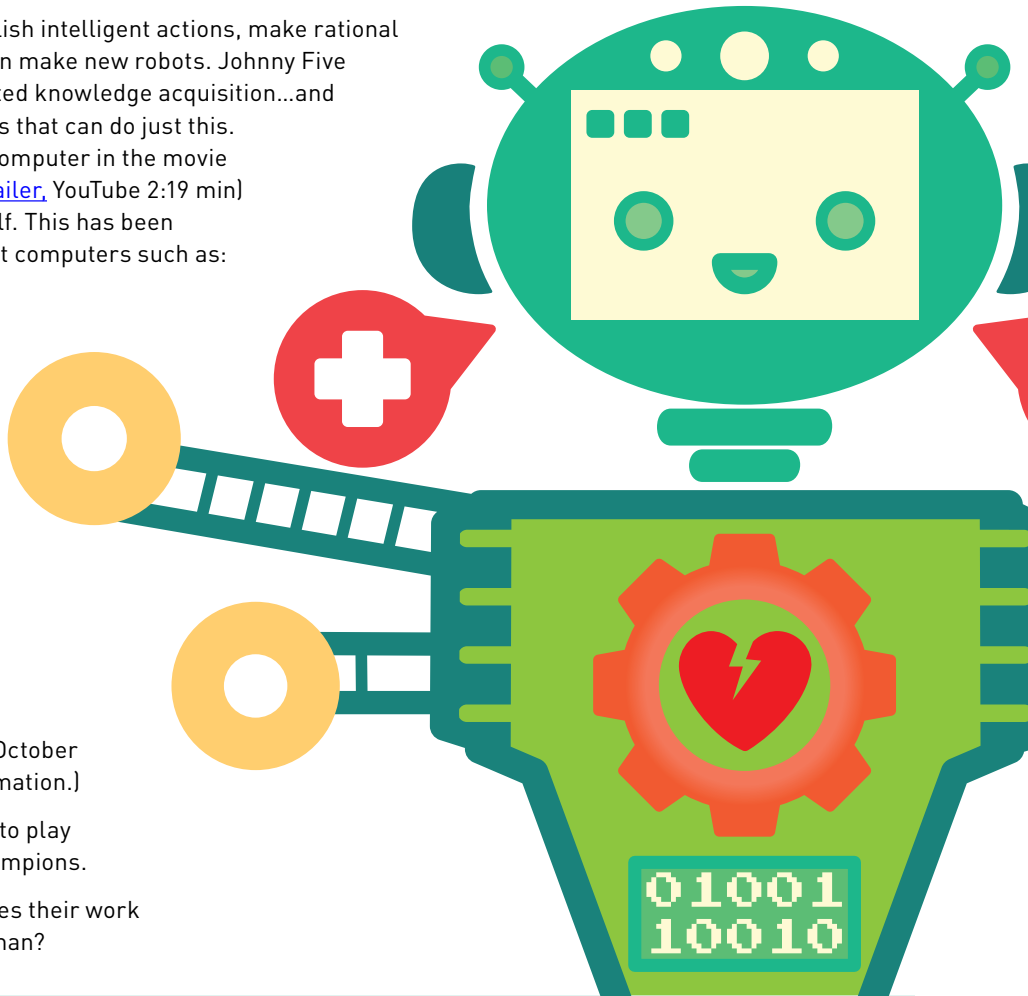

## VIDEO

To see what is happening in the area of cybernetics view the video:

[Could cyborgs really exist?](#)

Could humans be raised by a robot? Read about what a couple of experts think in the article [What's Mother's Day if you've been born in a machine and raised by robots?](#) *The Conversation*, 6 May 2016.

All the favourite fictional robots have characteristics and emotions that endear them to their human viewers. While today's robots are becoming more sophisticated and human-like, there are still differences in level of consciousness, autonomy and physical appearance between the real and fictional characters.

No matter how life-like some of today's robots appear the difference is still only skin deep. Social robots that are designed to be friendly, engaging and helpful are moving into the real world. These are more often humanoid in appearance and nature. Robotic intelligence is rising and serious scientists predict the development of human-like intelligence somewhere between 2029 and 2050. When this happens ethical and moral questions like 'Should robots be accorded rights?' will need to be answered. Should these robots be ethical? How do we build ethical robots? What will happen if we don't? Some of these questions have been considered in science fiction but now we have to apply them to reality...and sooner rather than later.

To read what some experts think about whether or not robots will take over the world read: [We ask the experts: Will robots take over the world?](#) 19 July 2013, University of Cambridge.

## Australian Research

### Killer Robots

*Professor Toby Walsh has been raising the issue of ethics and robots in relation to 'Killer Robots' used by the military. He shares his views below.*

#### What are killer robots?

Killer robots or, to give them their more formal name, 'lethal autonomous weapons' are weapon systems where a computer is used to identify a target, track that target, and ultimately destroy the target. People might think of the T-900 robot in the movie *Terminator*. However, we are talking about much simpler technologies. Think of the Predator drone that is flying above the skies of Afghanistan and Iraq today. That is not autonomous. It is flown by remote control, typically from a container back in Nevada. And a human makes the final life or death decision to fire the Hellfire missiles that it carries. However, it is a very small technical leap to replace that human with a computer, and have that computer make the final life or death decision. Indeed, the UK's Ministry of Defence have said that such weapons are technically possible today.

#### Do killer robots already exist?

There are a number of weapons systems already fielded by the military that would meet a strict definition of lethal autonomous weapons. For example, Samsung have produced a sentry robot that is used in the Demilitarized Zone between North and South Korea that is able to identify targets automatically from 4km away and shoot them with deadly accuracy. As another example, several ships in the Royal Australian Navy carry a Phalanx anti-missile system. This will identify, track and destroy incoming supersonic missiles. Because of the need to react in milliseconds, once switched on, it will work entirely automatically.

#### Why are some people worried about killer robots?

Killer robots have been called the 3rd revolution in warfare. The 1st revolution was the Chinese invention of gunpowder. This completely changed the nature of warfare from a very hands-on activity to one fought at a distance with a much deadlier outcome. The 2nd revolution was the invention of nuclear bombs. Again, this completely changed the nature of warfare to conflicts, which could destroy the whole human race. Lethal autonomous weapons will also be a step change in how we fight war, completely changing the efficiency with which we can kill the other side. For this reason, I organised thousands of researchers working in artificial intelligence (AI) and robotics to sign an Open Letter (<http://tinyurl.com/awletter>) calling upon the United Nations to pre-emptively ban offensive autonomous weapons.

#### What are some of the arguments for a ban on killer robots?

There is likely to be an arms race to develop these technologies. Unlike nuclear weapons, they will be cheap and will proliferate. They are likely to be sold on the black market and fall into the hands of rogue nations and terrorist organizations. They will be deadly efficient, able to work 24/7 without tiring. They will destabilize the current geo-political situation. And ultimately giving machines the right to decide if some lives or dies crosses a moral threshold.

#### What are some of the arguments against a ban on killer robots?

Robots could be more ethical and will not commit atrocities like humans do fighting wars today. Robots will simply be able to fight robots. We need to develop such technologies if we are to be able to defend ourselves against killer robots.



▲ Futuristic robot with weapons (©Scott Betts/123rf)

These technologies will be developed whatever we do. It will be much the same technology that goes into an autonomous car (and we'll surely want autonomous cars to prevent the thousand deaths per year on the roads of Australia). And weapon bans simply do work.

It is an interesting exercise to come up with counter-arguments to these arguments. For example, there have been a number of successful technologies banned (e.g. 1998 UN protocol on blinding lasers, and to a lesser extent the 1997 Ottawa Convention on anti-personnel mines).

#### What can you do?

- You can sign the [Open Letter](#) calling for a ban.
- You can watch a [TEDx talk](#) on this topic.
- You can join the [Campaign to Stop Killer Robots](#):

#### Where can you find out more?

[The Campaign to Stop Killer Robots](#), stopkillerrobots.org

[Killer robots](#), Human Rights Watch

[Killer robots](#), 31 March 2015, *Big Ideas*, ABC Radio National

[Killer Robots: The Third Revolution in Warfare](#), YouTube (54:36 min)

Prof. Toby Walsh  
UNSW and Data61  
Sydney  
Australia

[tw@cse.unsw.edu.au](mailto:tw@cse.unsw.edu.au)

<http://thefutureofai.blogspot.com>

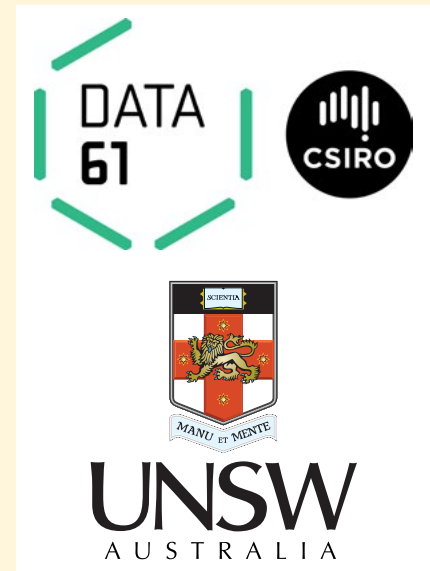

▼ [The Terminator](#) robot (Source: Wikimedia Commons, [stephen bowler](#), [CC BY 2.0](#))

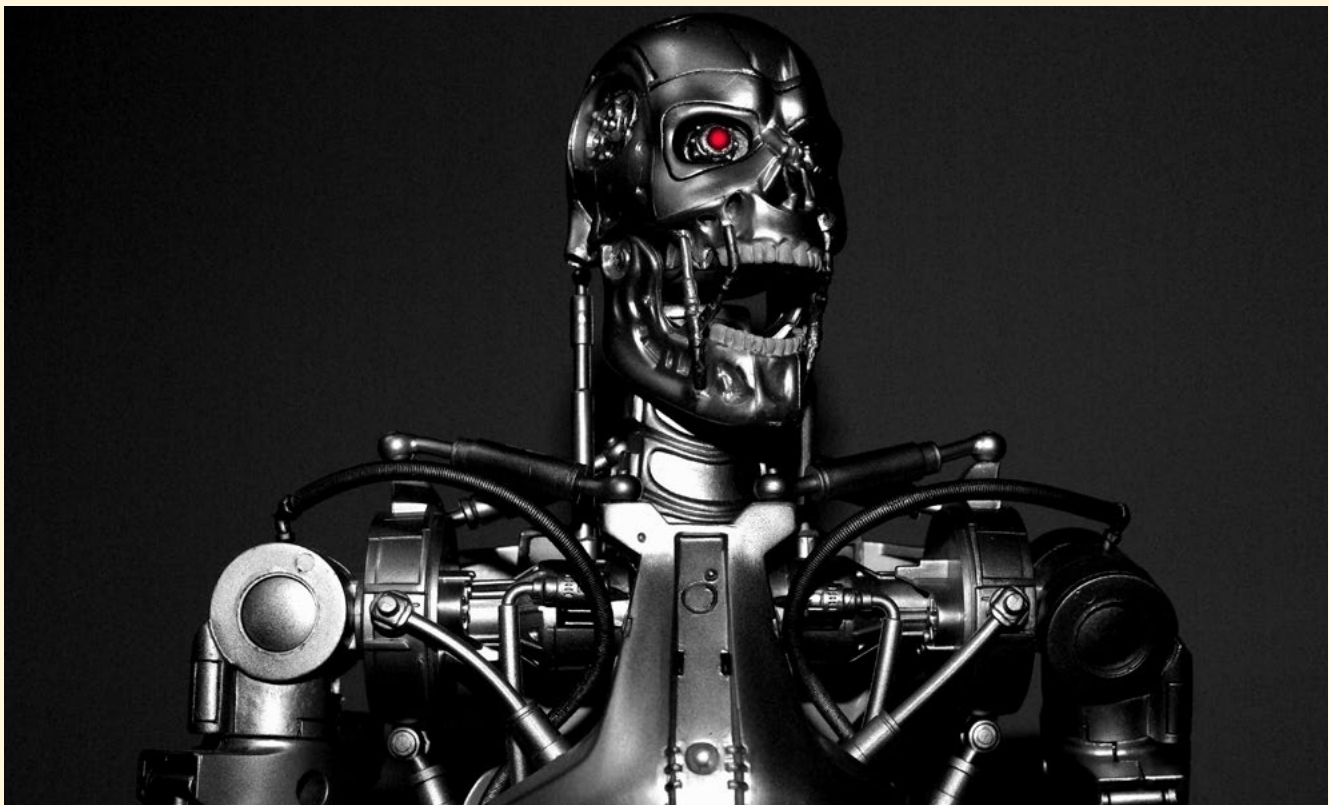

## CHAPTER 2: DRONES, DROIDS AND ROBOTS — WHAT'S THE DIFFERENCE?

*Everyone would agree that drones, droids and robots are 'machines' but what makes them different from each other and different from other machines?*

### Let's start with drones...

Drone technology has been around for a long time. The origins of drones can be traced back to the military. The first reusable radio-controlled aircraft built for target practice by the Royal Marines in the 1930s, is often considered the earliest version of the models used worldwide today. The first military drones with cameras were used as reconnaissance vehicles in the Vietnam War in the Sixties. More recently, military drones have been fitted with missiles as seen in the image below of a military predator drone.

▼ Military predator drone (Source: ©nerthuz/123rf)



▲ Piloting a radio controlled helicopter (Source: ©kletr/123rf)

#### Radio program

Listen to writer and artist Adam Rothstein presents a different kind of history of the drone: [What are drones?](#)  
29 May 2015, The List, ABC Radio National.

#### Timeline

To learn about the history of drones go to: [Timeline of UAVs](#), Spies That Fly, NOVA, PBS.

A drone is simply an unmanned aerial vehicle (UAV) that is operated autonomously or remotely, so a drone can be considered a flying robot. Most people use the word 'drone' to describe any aircraft without an on-board pilot but that is an over simplification.

Drones can vary in size from being as large as a full-sized aircraft or small enough to fit in the palm of your hand. It has been estimated that there are currently more than 1,500 different types of drones being manufactured today for a range of purposes.

Traditional model aircraft have been around for over a hundred years. Most are flown within a visual line of sight by an operator using a radio remote control. The operator maintains control of the airplane during the flight so these type of aircraft are not considered to be drones.

While the general public considers unmanned military aircraft, such as those that have been used by the US military in Iraq and Afghanistan, to be drones the pilots of these aircraft prefer the term UAV or RPA (remotely piloted aircraft). This is because it takes a high level of skill to remotely control the vehicles, many of which have controls comparable to those found in a traditional aircraft. UAV pilots often go through a rigorous screening then training process.

What about commercial and hobbyist drones? These are smaller versions are that used for all sorts of purposes by companies and individuals. This is discussed in more detail in Chapter 4.1, What's doing with drones?



▲ A drone used for aerial photography (Source ©jarp5/123rf)

Unmanned aircraft that fly using GPS to navigate a complex flight path without human control are definitely drones, as are those used by hobbyists. Many drone hobbyists have a high level of expertise and have merged robotics, sensors and airframe design to produce innovative aircraft.

The commercial and hobbyist drones have some level of autonomy so they can fly, hover or navigate without the input of a pilot...and this makes them an intelligent machine.

### ...and now to robots.

The origins of robotics go back to the automatons, such as a device to predict the position of celestial bodies, invented by ancient civilisations. The term 'robot' was first used by Czech writer Karel Capek in 1921 in a play called '[RUR](#)' or 'Rossum's Universal Robots'. In the play, a man creates a robot to replace him and then the robot kills him.

#### What is a robot and how is it different to a machine?

Most roboticists specify that robots have a reprogrammable brain (a computer) that moves a body. So while all robots are machines not all machines are robots. Any device capable of carrying out tasks independent of people can be called a robot. Robots are distinct from normal computers which don't have a physical body attached to them.

Another definition is that a robot is a computer that gathers data through sensors, can run analytics software to make sense of data it collects so it can undertake physical work. This definition adds a degree of intelligence to the robot. While there are robots that learn, many of the industrial robots that perform repetitive tasks are simply following their programming.

Robots collect sensor data, try to make sense of it using what they know, and then make a decision about what to do next. The smarter they are the better their responses. They might decide to move and perform an action like pick up an object, or wait until they get more information from their sensors before they decide what to do. Robots spend much of their lives gathering and analysing data, thinking about what the best next move is, and then actually doing it.

While automatons have been around for a long time it wasn't until the development of the computers that robots really developed. The time line below starts from this point.



▲ [A scene from the play R.U.R. showing the robots in rebellion](#)  
(Source: Wikipedia, Public Domain)

▼ Robots welding in an automobile factory (Source: ©Olga Serdyuk/123rf)

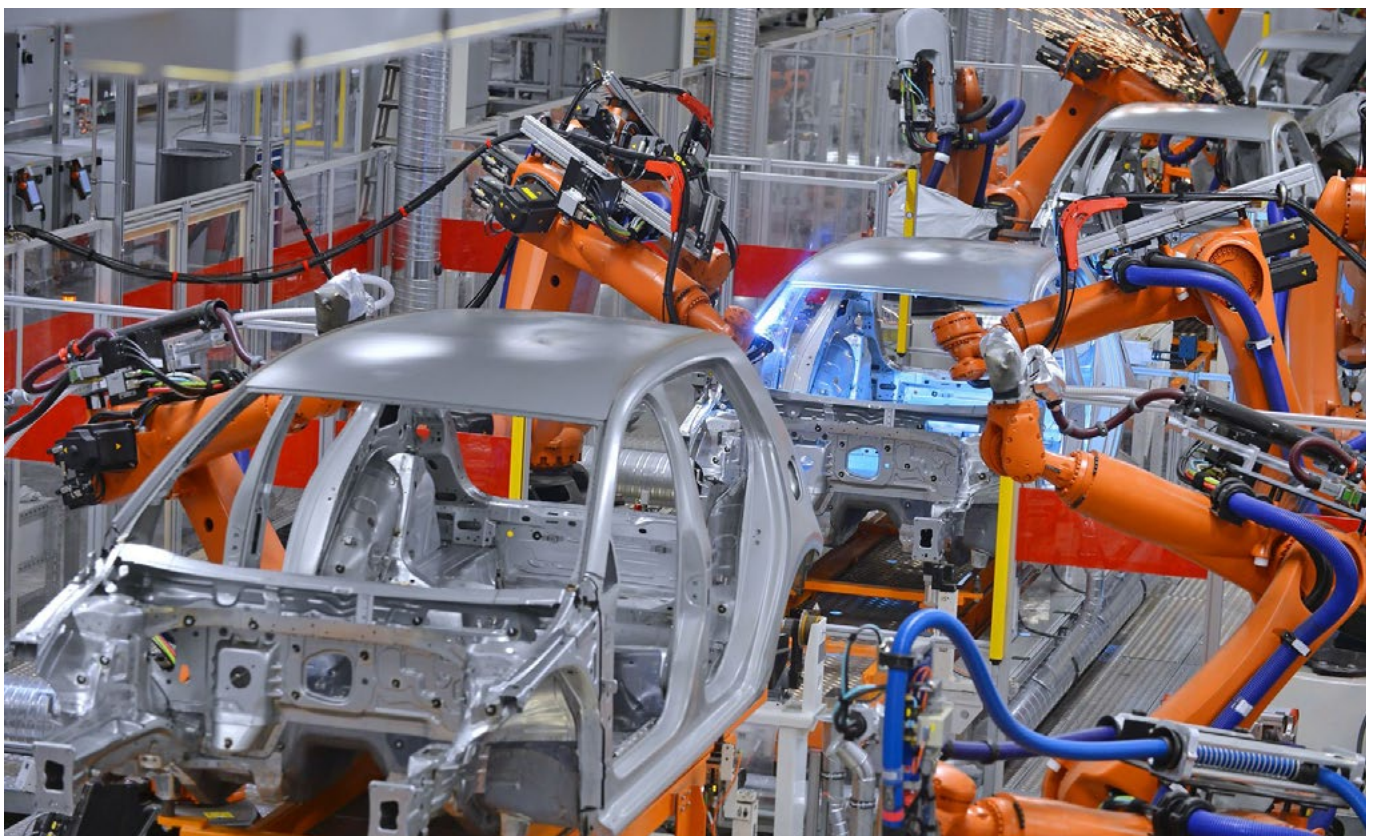

## Robot evolution

- 1936 — [Alan Turing](#) completes his paper '[On Computational Numbers](#)' which paves the way for modern computers
- 1937–1938 — [Westinghouse](#) creates [ELEKTRO](#), a human-like robot that could walk, talk and smoke
- 1943 — [Colossus](#), the world's first electronic computer is built in Britain to crack Nazi codes
- 1945 — [Eniac](#), which set the framework for post-war mainframe computers is turned on
- 1948 — [William Grey Walter](#) creates autonomous machines called [Elmer](#) and [Elsie](#)
- 1950 — [Alan Turing](#) proposes the [Turing Test](#) to decide if a computer is exhibiting intelligent behaviour
- 1954 — [George Devol](#) and [Joe Engelberger](#) create the first programmable robot arm. This later became the first industrial robot
- 1956 — The term 'artificial intelligence' ([AI](#)) is coined
- 1957 — The Soviet Union launches [Sputnik](#) the first artificial orbiting satellite
- 1964 — The [IBM 360](#) becomes the first computer to be mass produced
- 1966 — The [Stanford Research Institute](#) creates [Shakey](#), the first mobile robot that can reason about its surroundings
- 1969 — The [USA](#) uses the latest in computing to land [Neil Armstrong](#) on the moon
- 1973 — [Ichiro Kato](#) creates the [WABOT-1](#), a full-scale human-like robot with the mental ability of an 18 month-old child
- 1979 — [Hans Moravec](#) creates the [Stanford Cart](#), an autonomous vehicle that can navigate across a room full of obstacles
- 1985 — A biped robot was developed by [Hitachi Ltd](#)
- 1989 — [AquaRobot](#), a walking robot for undersea use was created at the Robotics Laboratory at the Ministry of Transport in Japan
- 1994 — Carnegie University use an eight-legged walking robot called [Dante II](#), to collect volcanic gas samples from the interior of the Mt Spurr volcano in Alaska
- 1996 — A robo-tuna developed by [MIT](#), [Honda](#) unveils the [P-2](#) humanoid robot that can walk, climb stairs and carry loads
- 1997 — [Sojourner](#), the first robot to visit Mars, performs scientific experiments on the Red Planet, [IBM's Deep Blue](#) computer beat world chess champion, Garry Kasparov, the first [RoboCup](#) tournament is held in Japan
- 1998 — Campbell Aird is fitted with the world's first bionic arm, [NASA](#) launches [Deep Space 1](#) autonomous spacecraft
- 1999 — US researchers build [Nursebot](#), designed to remind the elderly and infirm about daily activities and guide them through their homes, [Sony](#) releases the first [Aibo](#) electronic dog
- 2000 — The UN estimates that there are 742,500 industrial robots in use worldwide, [Honda](#) debuts [Asimo](#)
- 2001 — The [Global Hawk](#) robotic spyplane charts its own course
- 2002 — [iRobot](#) company release the first generation of [Roomba®](#) robotic vacuum cleaners
- 2003 — [NASA](#) launch twin robotic rovers called [Spirit](#) and [Sojourner](#) to Mars
- 2005 — Researchers at Cornell University build the first self-replicating robot
- 2006 — A 'robourgeon' performs the world's first unassisted surgical operation, treating a patient suffering from an irregular heart rate.
- 2010 — [Apple](#) debuts the [iPad](#)
- 2011 — [Apple](#) launches [Siri](#), [IBM's Watson](#) wins Jeopardy
- 2012 — [Google brain](#) teaches itself to recognise cats, the first driverless car is licensed in Nevada
- 2015 — [Zano](#), a nano-drone with an aerial phot and [HD](#) video platform is launched
- 2016 — [Google's DeepMind](#) program [AlphaGo](#) defeats international champion Lee Se-dol for a second time to take [Google DeepMind Challenge](#) series

## Australian Research

### Magic Lab, University of Technology Sydney (UTS)

Mary-Anne Williams is Research Professor and Director of the Innovation and Enterprise Research Laboratory (aka 'The Magic Lab') at UTS. Mary-Anne and her team, including Apple co-founder Steve Wozniak, are involved in a wide range of strategic research projects focused on disruptive innovation and emerging technologies, including socially-aware technologies like robots. She explains the ever-increasing place of robots in society.

Robots are pervading human society today at an ever-accelerating rate. They are breaking out of factories, where they are forced to do boring, dangerous and dirty jobs, into society, where they interact with and help people achieve more than they can alone.

You can find robots doing surgery in hospitals, serving food in restaurants, helping the elderly with their medication and teaching autistic children how to interact.

#### What can robots do?

Robots have been identified as a disruptive technology because they can do just about anything and in the future there really won't be anything that a human can do that a robot can't. Even today, robots have sensory powers beyond humans; they are stronger; more dexterous; more powerful than people.

Who saved the Earth when massive amounts of oil were pouring into the Mexican Gulf after a deep undersea accident? A robot! Who is exploring the furthest reaches of Solar System and beyond? A robot. Who is helping surgeons around the world perform delicate operations that require high-precision sensing and high-precision motion? A robot.

#### Why will robots totally change society?

Robots are having, and will continue to have, a profound impact on all aspects of society. As a disruptive technology robots will transform life, business, and the global economy. Facebook, Airbnb and Uber are good examples of disruptive technologies that have transformed existing industries because they drive innovation that creates new markets by displacing an earlier technology.



▼ UTS student Shaukat Abedi, Gutsy and Director of the Magic Lab, Professor Mary-Anne Williams (Source: ©The Magic Lab, UTS. Used with permission)

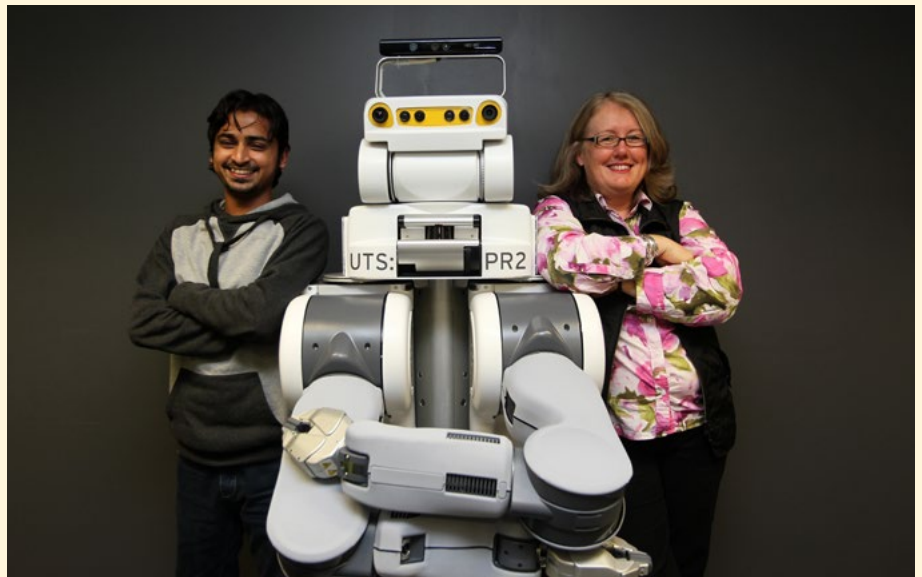

#### Scientific challenges for robots today

Robots need to become more sociable. They need to develop social intelligence and social skills that allow them to work fluently with people. Working with a robot should be fun and enjoyable, not infuriating and stressful. At UTS we have a social robot, called Gutsy. It's a great name because robots need to be brave, courageous and daring when they interact with humans. Social robots need to be creative problem solvers and have tons of emotional intelligence to work with people. They have to think ahead to figure out what is happening around them, to anticipate what people in the vicinity might do next, and be brave enough to do something useful to help them. Gutsy can express emotions including hugging humans while telling them it loves them. Gutsy's mission is to make humans happy.





◀ Steve Wozniak, co-founder of Apple, shares a hug with Gutsy. Woz is a Distinguished Professor in the Magic Lab. [Source: ©Srinivas Madhisetty. Used with permission]



◀ Gutsy attempting to change 8 week old baby Ida Brailey Madden's nappy. Should Gutsy delete all the images collected for this task? What might happen if Gutsy was hacked? A human nanny couldn't be hacked and collected images stolen and misused. Many new legal and ethical questions arise when robots work closely with humans. [Source: ©Mary-Anne Williams. Used with permission]

### Legal and ethical challenges that arise when robots work with people

There are many critical questions that need to be addressed when designing social robots. In every human-robot interaction there is a risk of harm to people. Physical harm can occur if a robot does not predict a person's movement correctly: it may collide with them and cause injury. Robot sensory perception and choice of response will never be perfect. Since robots collect a lot of data they might use this data in inappropriate ways like discriminating against certain humans, or selling it on the Internet. Even worse a robot could be hacked and the data used to cause significant harm. Consider if someone hacks your home robot to discover when you are home or not, in order to perform the perfect robbery. A hacker could connect to your robot and write a program that instructed your robot to open the door and let them in.

Find out about what happened when Gutsy 'escaped' by watching the video [The fugitive: A robots quest for freedom](#), YouTube (2:36 min)

For more information on The Magic Lab see [The Magic Lab website](#).

For more information on disruptive innovation see McKinsey Global Institute. 2013. [Disruptive technologies: Advances that will transform life, business and the global economy](#), McKinsey and Company website

## What about droids?

The term 'droid' was first used in a 1952 sci-fi story by Mari Wolf, *Robots of the World! Arise!* published in *IF — Worlds of Science Fiction*, July 1952 (The story can be downloaded freely from [TES Australia](#))

The word 'droid' is a derivative of 'android'. The term 'android' appears in US patents in reference to miniature human-like toy automations as early as 1863. Androids are robots but not all robots are androids. While a robot can, but does not necessarily have human form, an android is always in the form of a human.

If this means having a similar body structure, then there are many humanoid robots that are androids. If it means they should be able to pass for a human, like Data from *Star Trek: Next Generation*, then most androids are creations of science fiction.

There are, however, several projects aiming to create androids. The Intelligent Robotics Lab at Osaka University released the Actroid in 2005 and the Telenoid R1 in 2010.

The Korean Institute of Industrial Technology (KITECH) has developed the EveR-1. She is an android matching the average figure of a Korean woman in her twenties. She is able to demonstrate realistic facial expressions and sing while simultaneously dancing.



◀ **EveR-2**, a female android developed by the Korea Institute of Industrial Technology and demonstrated to the public in October 2006. It is 165cm tall and weighs 60kg. [Source: Wikipedia, ©[Korea Institute of Industrial Technology](#)]

Other android projects are being conducted in Singapore and the United states.

### VIDEO

To see how nature is being used as inspiration for developing new kinds of robots watch the video: [Bioinspired Robotics: Smarter, Softer, Safer](#), YouTube (6:23 min)



▲ **Actroid DER**, developed by [KOKORO Inc.](#) for customer service appeared in the 2005 Expo Aichi Japan. The robot responds to commands in Japanese, Chinese, Korean and English. [Source: Wikipedia, [CC BY-SA 3.0](#)]

So to summarise — what's the difference?

**Drones, droids and robots are all machines. Drones are robots which fly and (an)droids are robots which look like humans.**

### Teaching resources

RiAus and SA DECD. 2014. [STEM Careers Pack 7: Follow your interest in ... Robotics. RIAus](#), (Sequential set of tasks and information for years 7–10).

'[Robotics — Lesson Plans](#)', NASA.

Carnegie Science Centre. nd. [ASIMO Classroom activities](#), ASIMO Honda.

## CHAPTER 3: INTERACTIVE LEARNING — LEARNING IN DISGUISE!

This chapter provides information on, and direct links to, interactive games, quizzes, learning objects and apps for students from years – 10, but primarily for younger students. There is also a section with information for teachers on programmable robots.

### Direct a robot

A series of three interactives:

#### 1. Direct a robot: collector

TLF ID L753

Recommended Year level: 2, 3 (Guided); 4, 5

Possible curriculum applications: Science / Mathematics / Geography

Give directions for a robot to collect rock samples on the moon. Plan the most direct route to save fuel. Enter direction and distance for each step.

<http://www.scottle.edu.au/ec/viewing/L753/index.html>

#### 2. Direct a robot: which way?

TLF ID L1074

Recommended Year level: 2, 3 (Guided); 4, 5

Possible curriculum applications: Science / Mathematics / Geography

Give directions to a robot to collect rock samples on the moon. Plan the most direct route to save fuel. Enter the best direction for each step. This is the second in a series of three interactives.

<http://www.scottle.edu.au/ec/viewing/L1074/index.html>

#### 3. Direct a robot: how far?

TLF ID L1075

Recommended Year level: 2, 3 (Guided); 4, 5

Possible curriculum applications: Science / Mathematics / Geography

Give directions to a robot to collect rock samples on the moon. Plan the most direct route to save fuel. Enter the distance for each step. This is the third in a series of three interactives.

<http://www.scottle.edu.au/ec/viewing/L1075/index.html>

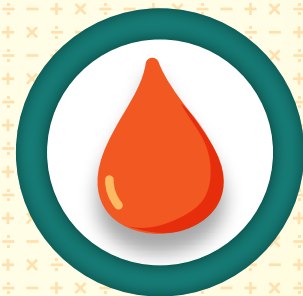
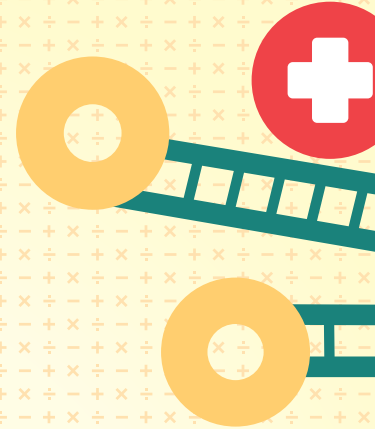

## Robots: make a catalogue

TLF ID L5995

Recommended Year levels: 5, 6, 7

Possible curriculum applications: Science / English

Explore facts about a robot designed to enter dangerous situations. Choose parts to build a companion robot and an underwater robot. Build explanations about the features of each robot. Complete an advertising catalogue explaining the features of each robot.

<http://www.scootle.edu.au/ec/viewing/L5995/index.html>

## Volcanoes (with spoken instructions)

TLF ID L13

Recommended Year level: Foundation, 1-2

Possible curriculum applications: Science / Geography

Direct a robot to examine a volcano. Measure temperature inside the volcano and collect samples of rock from different areas within the volcano. View images of rock samples and match samples to their location.

<https://www.scootle.edu.au/ec/resolve/view/L13>

[This interactive is also available without spoken instructions (TLF ID L197)]

## Bee-bot App (Free download)

The new Bee-Bot app has been developed based on the Bee-Bot floor robot. The app makes use of Bee-Bot's keypad functionality and enables children to improve their skills in directional language and programming through sequences of forwards, backwards, left and right 90 degree turns.

The app has been developed with 12 levels, with each level timed and the faster it is completed the more stars are earned.

The app is for iPhone®, iPad® and iPod touch®.

<https://itunes.apple.com/au/app/bee-bot/id500131639?mt=8>

## Programmable robots

### Bee-bot programmable robots

Recommended Year levels: Foundation – 6 (Primary)

Possible curriculum applications: Science / Digital technology / Mathematics / Literacy

Bee-bots are small, programmable robots specially designed for children. Program each bee-bot to follow instructions; move forwards and backwards, turn left and right and 90 degrees. Use bee-bots to teach sequencing, estimation, direction and to solve problems. Specially designed mats allow a variety of challenges suited to the areas of mathematics and literacy.

<https://www.bee-bot.us/>

Bee-bots Australia (MTA) <http://www.teaching.com.au/catalogue?catalogue=MTA&category=MTA-BEE-BOTS-EARLY-YEARS-ROBOTICS>

## LEGO® Mindstorms

**Recommended year levels: Foundation – Senior**

LEGO® Mindstorms is a kit system of hardware and software to create customizable, programmable robots. They include an intelligent brick computer that controls the system, a set of modular sensors and motors, and Lego parts from the Technic line to create the mechanical systems.

Use the robots in conjunction with specially designed apps to enhance activities.

<http://www.lego.com/en-us/mindstorms/?domainredir=mindstorms.lego.com>

## Dash and Dot robots

**Recommended Year levels: Foundation – 5**

**Possible curriculum applications: Science / Digital technology / Mathematics**

Dash and Dot programmable robots are used in conjunction with child-friendly apps that allow students to use coding languages easily and quickly. Students use the apps to program the robots to play a variety of games. Add attachments to enhance the games and robot's actions.

<https://www.makewonder.com/>

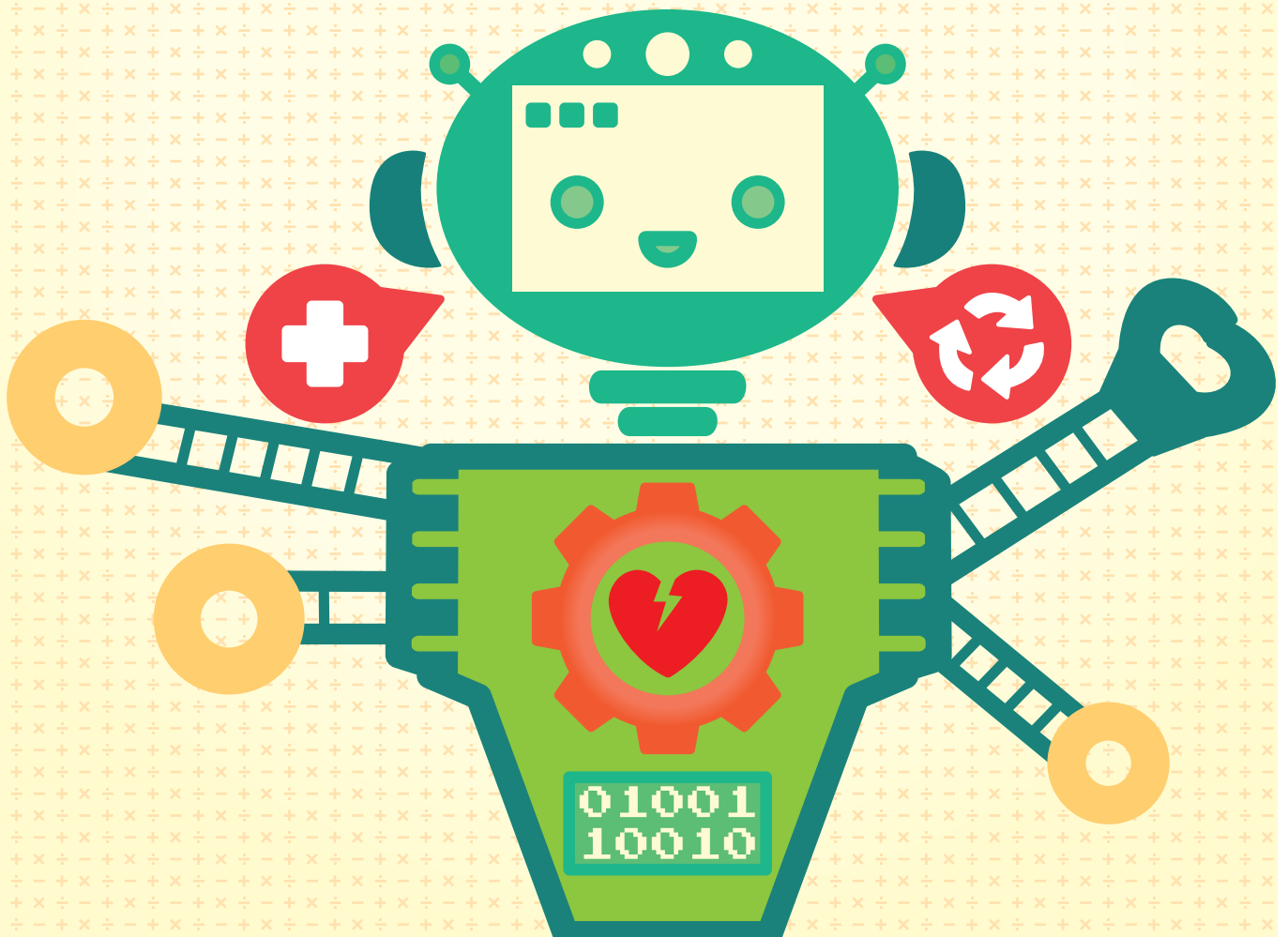

## CHAPTER 4: HOW DO WE USE DRONES, DROIDS AND ROBOTS?

### 4.1 What's doing with drones?

*This section will explore some of what is happening in the world of drones. Drone technology has been around for a long time. Initially drones were developed and used for military purposes with the first pilotless aircraft built during and shortly after World War I. Drones have come a long way since then. They have gone from being the province of the military to having a variety of commercial application...and as a toy for children.*

#### STUDENT ACTIVITY: DRONES

In this activity you will be investigating a current, existing use of a drone.

Your job is to research your chosen device and answer the following questions.

1. What is the purpose of your device and what problem does it solve?
2. Describe how the device makes a contribution to one or more of the following?
  - environmental problems
  - personal needs of people
  - community issues
3. Provide details on how the device is powered.
4. Describe how the operator and device communicate with each other.
5. How is the device controlled and/or programmed?
6. Who uses your chosen device?
7. Describe any issues that might be associated with the use of the device. Some possible issues you could discuss are safety, privacy, environmental damage, laws and legislation.
8. Evaluate your device by comparing and weighing up its benefits and limitations.
9. Propose possible modifications or improvements that would enable your chosen device be applied more widely and to a greater variety of circumstances?



◀ [Drone first test flight](#), Richard Unten, Flickr, [CC BY 2.0](#)

**What's new in the world of recreational drones?**

At Christmas 2015, advertisers were trying to wow kids and their parents with drones from as little as \$48. Even the sophisticated Parrot Bebop which carries a full high definition 14 megapixel camera, stabilised on a 3-axis framework was only \$687. For the beach, there was the Mariner Waterproof quadcopter, which can take off from water and also fly upside down in the water with GPS disengaged.

**VIDEOS**

[Parrot Behop Drone — Official video](#), YouTube (2:47 min)

[Mariner waterproof quadcopter in-water tests](#), YouTube (4:26 min)

Although a drone is defined as an unmanned aerial vehicle (UAV), without a human pilot aboard, the vast majority are designed to carry a camera. In addition, the flight of drones may be controlled either autonomously by onboard computers or by the remote control of a pilot.

The drones on show at the 2016 Consumer Electronics Show (CES) in Las Vegas, typically had cameras with 4K resolution. This means the display has horizontal resolution in the order of 4,000 pixels, which is currently the standard for Ultra High Definition consumer televisions. More pixels mean more information which means sharper pictures, which are much more engaging and desirable.

One exhibit at CES, a prototype of the self-driving drone, *Lily* acts as a robot videographer, automatically following the user anywhere. *Lily* starts recording video as soon as it is tossed into the air and is even waterproof, so can be used at the beach or pool. Surprisingly, *Lily* had very successful sales even before it was on the market. By the end of 2015, 60,000 units had already been sold netting US\$34 million in pre-orders.

**VIDEOS**

To see features of the Lily drone and how it works, view the video embedded in the article [Lily, A camera that automatically follows you pulls in a mountainous 34 million in pre orders](#), Techcrunch (2:46 min)

The Loon Copter is a drone that can fly, float or swim underwater. To see it in operation view the video [Loon copter: the air + surface + underwater drone \(winner of 2016 'Drones for Good' competition\)](#), YouTube (3:01 min)

The world's biggest market for drones is the United States, but manufacturers are beginning to look to expand their markets by moving into Asia, in particular South Korea, Japan and China. At the same time, electronics factories, like those in Shenzhen in China, are turning to the manufacture of consumer drones to boost their profits. They will be searching for the latest innovation to make their products stand out from the rest.

**When things go wrong**

Drones are readily available and given their speed and size, they pose a risk if flown without care, training or suitable skills. Those with attached cameras, also bring privacy concerns.

While the vast majority of operators fly safely, there is concern that people might be tempted to fly drones when they shouldn't, especially in emergency situations such as bushfires, flood and traffic accidents. In terms of safety, there are serious issues around the possibility of drones colliding with aeroplanes.

With the United States Federal Aviation Administration, receiving more than 25 reports a month of drones flying too close to crewed aircraft, this is a distinct possibility. As drones are generally very small, they are often not seen until they are too close for the pilot to take evasive action. Airline pilots are now asking for testing to be done on the likely consequences of a collision with a drone.

**VIDEO**

To hear more about the challenges of maintaining safety with drones view the video [SAFEGUARD: reliable safety net technology for unmanned aircraft systems](#), YouTube (4:38 min)

In 2013, in Australia, a UAV collided with the Sydney Harbour Bridge (see '[Mystery drone collides with Sydney Harbour Bridge](#)' 4 October 2013, Sydney Morning Herald), although apparently no one was injured, while in January 2015 a drone accidentally crash-landed on the White House lawn in the USA causing a security alert (see '[A drone, too small for radar to detect, rattle the White House](#)', 26 January 2015, New York Times). Of more concern was the report that in November 2015, an English toddler lost an eye as a result of a runaway drone (see '[Toddler's eye sliced in half by drone propeller](#)', 26 November 2015, BBC News). In another accident the previous year, this time in Australia, a drone being used to photograph competitors in a triathlon, crashed into an athlete causing head injuries that required stitching (see '[Triathlete injured as drone filming race falls to ground](#)', 8 April 2014, ABC News).

Further concerns relate to privacy. In Australia, the Civil Aviation Safety Authority already prohibits the use of drones on beaches or within 30 metres of another person. Yet, so many people have complained about drones flying near their houses that a growing number of councils are moving to ban or restrict their use in local parks. The solution for some cities is dedicated flying fields well away from domestic housing. For example, 30 km south of Perth, in the town of Kalamunda, a 24 ha area provides an open space that is shared by drone enthusiasts and model aeroplane hobbyists.



◀ No drone symbol mark for privacy protection concept  
Source: (@cheskyw/123rf)

**VIDEO**

To hear about some of the concerns about drone safety view the video [Rise of the machines: drones](#), ABC Splash (3:34 min)

**Both criminals and the police use drones**

The criminal use of drones is becoming a concern as these vehicles become cheaper and more common. For example, drones are being seen an easy way of transporting drugs across the borders between one country and another. Even though drones are limited in how much they can carry, they have a huge advantage in being very difficult to detect; 'flying under the radar' so to speak.

In 2015, 12 kg of heroin was smuggled by drone across the U.S. border near Calexico, near San Diego. The two men who pleaded guilty were caught on Border Patrol cameras on retrieving the drugs near California Highway 98 in Imperial County. According to court records, U.S. law enforcement officials called drug-carrying drones an emerging threat. (See [Two youngsters found guilty of drug trafficking with drones](#), 14 August 2015, Borderland Beat)

Another area of concern was highlighted when a man was recently convicted of using a drone to stalk and photograph bathers at Perth's Cottesloe Beach. Worse still, when police searched his house, he was found to have a suite of surveillance devices and concerning images on his computers (see '[Man likely to be charged after allegedly using drone to take revealing beach photos](#)', 5 March 2016, The Australian).



In regards to law enforcement, in most states in Australia, drones are being used as a tool to help fight crime and to assist in rescue missions. For example, the aerial views that drones capture make them an attractive tool for police surveillance, recreating crimes scenes and searching for lost hikers.

In spite of the many benefits, some people are not in favour of the widespread use of drones by the police. The main concern from the public is that drones could unintentionally capture footage of people going about their normal life. Another concern is whether police will receive proper training in operating drones before they are given appropriate licenses by the relevant civil aviation authorities — especially since training can be quite expensive.

As with any other technological innovation, the use of drones by the police will require careful deliberation, proper testing and the establishment of relevant legislation.

## VIDEO

To hear about the police perspective view the video [Rise of the machines: using drones](#), ABC Splash (2:19 min)

## Drones in agriculture

Farmers are enlisting the help of drones to keep an eye on crops, with a view to increasing their yields.

When needed, drones fly around the property autonomously, using various types of cameras to take photographs of selected areas. They are then put together to produce a map that relates to the crop health of the farm. The map can then be used to make decisions about how to best manage the crop for the greatest yield. In addition, when a drone is used to survey a crop at regular intervals, the combined imagery can reveal trouble spots as they develop and opportunities for better crop management.

Seeing a crop from the air in this way can reveal patterns that expose everything from irrigation problems to soil variation and even pest and fungal infestations that are not apparent at eye level. If the cameras used can take multispectral images that capture data from the infrared as well as the visual spectrum, they can create a view of the crop that highlights differences between healthy and distressed plants in a way that cannot be seen with the naked eye.

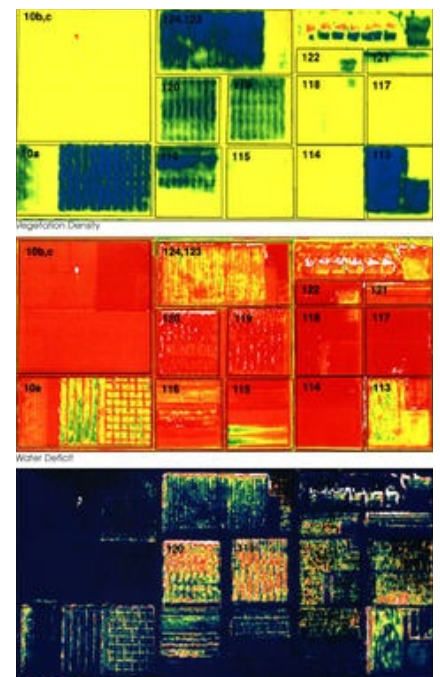

▲ **Examples of remote sensing in agriculture.** Top to bottom: vegetation density, water deficit and crop stress. [Source: The Conversation Susan Moran/NASA]

◀ Hexacopter UAV drone in support of agriculture [Source: ©Nir Naamat/123rf]

## Australian Research

Students at The University of Queensland's (UQ) Gatton campus are using the latest in drone technology to address biosecurity, sustainability and diminishing resources, economic and environmental issues.



### Drone technology gives farmers an edge

Precision agriculture, focusing on automated farming and improving agricultural production systems, has become an important course taught at Gatton with drones incorporated into student learning.

UQ's Associate Professor Kim Bryceson, said students have access to a fleet of five quadcopters and three hexicopters which they use to collect data on spatial variability and crop health.

"Tools such as drones equip students with the knowledge to assist farmers in increasing production efficiency and quality whilst minimising cost, risk and environmental impacts," said Assoc. Prof. Bryceson.

UQ drones are simple, cheap to run and provide robust platforms for many different sensors to deliver data and information that current farm managers and research scientists use right now.

"Our science, agriculture and wildlife students worked with local farmers and agribusinesses on some pilot projects over summer, she said

"By simply incorporating additional elements, we have been able to increase the utility of a drone and design it for the specific applications that we need.

"Some of these modifications include adding an automated container to drop beneficial insects on crops to reduce the use of pesticides and increase production; designing a drone to fly like a falcon to keep crows away from melon crops or being fitted with multispectral and thermal imaging cameras to assist with rabbit control, crop quality analysis and weed detection."

Ranked as the top agricultural research university in Australia and in the top twenty agricultural research universities in the world, UQ provides exceptional learning opportunities for undergraduate or postgraduate students.

### VIDEO:

[Bird's-eye view to improve farming](#), YouTube (1:29)



▲ Fitted with visual, multispectral and thermal imaging cameras, the drones can be used for work on rabbit control, beneficial insect drops to reduce pesticide use, crop quality analysis, and weed detection (Source: ©The University of Queensland. Used with permission)

◀ UQ agriculture students can collect data on the health of their crops using quadcopters and hexicopters (Source: ©The University of Queensland. Used with permission)

### Drones and mining

By doing the job of mining surveyors, drones are playing a leading role in a central Queensland coalmine at Goonyella. Looking like a model aeroplane, the drones have a flight time of around 40 minutes and can fly up to 80 km/h at a height of 120 m. They are programmed to fly autonomously over the mine site while snapping overlapping photographic images. These are photographs are then used to build 3D models of the mine site, which is 30 km long and 20 km wide (see [Drones take BHP Billiton's mining survey work to higher levels](#), 5 March 2016, The Australian).

Rio Tinto is also using drones to monitor sites and inspect equipment. (See [Blue sky thinking: how drones are helping Rio Tinto improve decision making](#) Rio Tinto website.)

The benefits are significant. The area photographed in a single flight would take mining surveyors on the ground many weeks to cover. In addition, the high accuracy of the resultant data is giving engineers, operators and the surveyors themselves, a much better understanding of what is happening at their mine site. This means better safety and productivity.

#### VIDEO

To see an example of this 3D mapping view the video [What is Hovermap?](#) ABC Splash (2:22 min)

### Using drones in conservation

With enough personnel, it is relatively straightforward to carry out surveillance operations to protect rhinos during the day in South African game parks. The rangers can see and avoid dangerous wild animals like lions and buffalo, while they walk around looking for poachers. At night, when it is pitch black, it is a different story. They cannot see the poachers or the wild animals. The solution is to each night send out a drone fitted with infrared cameras. Captured aerial images across the park are transmitted back to the command centre so that rangers on the ground can be warned if any dangerous animals or poachers are nearby.

To learn more about how drones are being used to take down poachers in Africa see the article [Satellites, mathematics and drones take down poachers in Africa](#), Thomas Snitch, The Conversation.

Drones are also being used in SE Asian rainforests to help provide accurate information on orangutan populations. See the articles [Using drones to improve orangutan conservation](#), 11 March 2016, Conserve website and [Conservation drone project](#), Orangutan Conservancy website.

Tracking Australian animals over vast and varied landscapes can be very difficult for animal researchers. Drones are revolutionising the way researchers track endangered Australian animals.

#### VIDEO

To see how drones are used to track endangered Australian animals watch the video [Drones track endangered Australian animals](#), ABC Splash (2:01 min)

► [Collage of orangutan nests](#). Images taken by conservation drones (Source: Lian Pin Kih, Flickr, [CC BY 2.0](#))

▼ [A drone used to track poachers](#) (Source: The Conversation, Thomas Snitch, [CC BY-NC-ND](#))



## Australian Research

Palaeontologists at The University of Queensland (UQ) are using drone technology to capture new information that will help bring a 130 million-year-old dinosaur landscape back to life.



### Race to record dinosaur tracks

Dr Steve Salisbury and his team from UQ have been using drones to hunt for signs of dinosaurs along the 'Dinosaur Coast' in the remote Kimberley region of Western Australia.

Palaeontologist and dinosaur track expert Dr Anthony Romilio said the team was documenting fossilised dinosaur tracks to better understand what sorts of dinosaurs inhabited Australia 130 million years ago.

"The sandstone that the tracks occur in crops out along the seashore, at sites scattered along roughly 100 km of coastline," he said.

"Because of the extreme tides in this part of Australia, the rock platforms we're working on are only visible for a short window each day, and sometimes for only a few days each year.

"This means we have to work very quickly, before the tracks go underwater."

The project uses the latest mapping technology, including a remote-controlled aerial drone, a hand-held laser-scanner developed by CSIRO, and a specially equipped remote-sensing survey plane.

"We take overlapping sets of high-resolution photographs of individual tracks and entire rock platforms, which we later convert into 3D digital models."

"We also take physical moulds of tracks using a rapid-setting silicon rubber which can then be used to produce rigid plastic replicas back at UQ.

Despite recent National Heritage Listing of the Dampier Peninsula's dinosaur tracks, many of the tracks remain largely undocumented and their full scientific significance is poorly understood.

"The results of this project should allow us to construct high-resolution, 3D digital outcrop models of the track sites, and bring the 130 million-year-old landscapes back to life."

The team also works closely with Goolarabooloo Traditional Custodians and Yawuru Native Title holders, as the dinosaur tracks form an important part of a song cycle that extends along the coastline.



▲ Goolarabooloo Law Boss Phillip Roe, Dr Steve Salisbury and Linda Pollard use the dino-drone. (Source: ©Damian Kelly. Used with permission)

**Attack drones: drones vs pests**

Drone technology is now being used to specifically target agricultural pests, like weeds insects and birds.

In Bundaberg, Queensland, agriculturalists at *Sweet Sensations Farm* have been working closely with Central Queensland University in using remote-controlled drones to scare birds and bats from their crops of avocados, lychees and macadamia nuts. So far, they have been able to reduce crop losses due to bats and birds, from about 30 per cent to 5 per cent. (See Buchanan, Kallee. [Using drones to scare off flying foxes could help lychee industry expand](#), 9 October 2015, ABC Rural.)

In Japan, drones have been used for crop-dusting for more than two decades. Such drones use a wave radar to scan the terrain below in real-time. This enables them to automatically maintain a suitable altitude and distance from crops to facilitate an even spray of pesticide. One impressive recent development is an intelligent memory system. After the drone is brought back to base to refill its tank or recharge its battery, it returns to its remembered position and resumes spraying where it left off.

The next step will be to move away from this blanket spraying approach to a very targeted system. In an Australian first, cattle graziers in Queensland are using drones in two different ways to target an invasive tree pest that threatens their prime pastoral land. The prickly acacia tree, introduced to Australia from India, is already widespread on several million hectares of Mitchell grass plains in far-western Queensland. It forms dense, thorny thickets that decrease the growth of pasture grasses, degrade soil, threaten biodiversity and interfere with stock movement.

The helicopter-like drone, purchased by a group of graziers for a cost of \$140,000, can fly as low as 3 metres above the trees, dropping herbicide pellets, directly onto the weeds. The amazing accuracy has the benefit of preventing native plants from being unintentionally poisoned. It is possible because another drone, called J3 Cub, had been previously used to detect and map the acacia distribution over Northern Queensland. (See [One million prickly acacia deaths by DCQ](#), 22 July 2014, ABC Rural).



▲ Quadcopter over field (Source: ©zych/123rf)

In a similar innovation, the [Australian Centre for Field Robotics \(ACFR\)](#) at Sydney University has developed a drone-like helicopter that can fly around a property and use cameras to automatically identify in real time where weeds are actually growing. The drone also has the capability to selectively spray herbicide just on those weeds.

Automated systems, using drone technology to detect and specifically target weeds, have many benefits. They considerably reduce environmental pollution from overspray, protect non-target species and are much cheaper than conventional spraying as far less herbicide is used.

### The future of commercial delivery drones

One of the hopes of many companies, including Google and Amazon, is that in the near future drones will be able to deliver packages and letters directly to their customers. Critical to their success will be the management of drone traffic.

Australian start up company, Flirtey, is claiming to be the first drone company to make an approved commercial delivery in the U.S. Matt Sweeny, drone entrepreneur and CEO of Flirtey, believes that in the future delivery by drone will become ubiquitous, despite the current concerns regarding safety and privacy.

#### VIDEO

Hear about the story of Flirtey on [Game of Drones](#). 17 May 2016, Foreign Correspondent, ABC TV (28:41 min)

It is therefore interesting that Frank Appel, the head of Deutsche Post-DHL, the world's biggest postal and logistics company, does not believe that drone delivery services will ever become mainstream. He believes that people's privacy concerns will create enough pressure on governments for them to pass very strict regulations that would prevent the widespread use of drones for delivery purposes. Instead, he believes that driverless cars will be the couriers of the future.



◀ [In December 2013, the German Deutsche Post AG tested a microdrone md4-1000 for delivery](#)  
 (Source: Wikimedia, Frankhoffner [CC BY-SA 3.0](#))

#### ARTICLE AND VIDEO

To see how deliveries might work in the future see the article '[Google and Amazon talk about managing drone traffic at CES](#)' and the accompanying embedded video 'Amazon Prime Air' (2:16 min)

### Drones taking the heat

Research is currently underway to use drones as 'eyes in the sky' to help not only urban fire fighters but also to help manage and monitor bush fires.

At the University of Nebraska-Lincoln in the U.S., researchers are developing a drone that can ignite and monitor controlled burns. The drones would carry pin-pong-like balls filled with potassium permanganate powder. These would be injected with liquid glycol, creating a chemical reaction-based flame, before being dropped through a chute to the ground below. The goal is to ensure a safe mechanism for fire management staff with lower risk and great efficiency. (See Reagan, Jason. [Drone System Fights Fires with Fire](#), 3 May 2016, Dronelife.com)

The Fireproof Aerial RObot System (FAROS) is the new firefighting drone from the Korea Advanced Institute of Science and Technology (KAIST). FAROS can 'not only detect fires in the tallest of skyscrapers, it can also search an engulfed building and transfer real-time data to human firefighters. It cannot only fly but also climb walls, is fireproof (it is coated with 'aramid' fibres; a cross between artificial asbestos and Kevlar) and can withstand heat in excess of 1,000°C. (See Reagan, Jason. [Korean firefighting drone takes the heat](#), 27 January 2016, Dronelife.com)

#### VIDEO

See Faros in action in the video [Fireproof Aerial RObot System \(FAROS\)](#), YouTube (2:26 min)

## Australian Research



### Disposable drone technology fighting fires

In 2015 the Australian government brought a series of complex autonomous drones for \$20 million dollars each.

Not all drones are this expensive, but it's certainly true that the more complex the drone technology, the more expensive the price tag.

It's easy to justify spending a lot of money on a drone if you know you're going to be using it for a long time, but what happens when you need to send your drone into a dangerous situation where you know it is unlikely to survive its first flight?

Dr Paul Pounds, an Engineer at The University of Queensland, is working to solve this problem by developing smaller, disposable unmanned aerial vehicles (UAVs).

"One of my current projects is working on a UAV shaped like a samara seed which can be deployed during bush fires," Dr Pounds said.

Detecting, monitoring and fighting bush fires is a lot easier when you have extremely localised, accurate and timely information about changing weather conditions, but traditional methods of gathering this information can be dangerous and costly.

"Using a long-range mothership drone, we can scatter these smaller UAVs around the landscape where the fire is taking place," Dr Pounds said.

"The mono-wings allow them to autorotate and land softly, while a series of sensors allows it to detect movement, temperature, humidity readings for about a week."

"We also get a GPS measurement from the device when it initially lands."

The battery in each unit lasts about a week, and when a fire front approaches the device the sensors can use any remaining on board energy to send out an alert signal — kind of like a fire alarm for the bush.

"Currently the UAV is still in the design phase, so they cost around \$100 to construct a single unit, but once the design is finalised and they go into mass production the price is likely to drop to around \$20 each," Dr Pounds said.

"That's affordable enough that emergency services can deploy them during bush fires, without worrying too much if some of them are destroyed by fire or fail in the field."

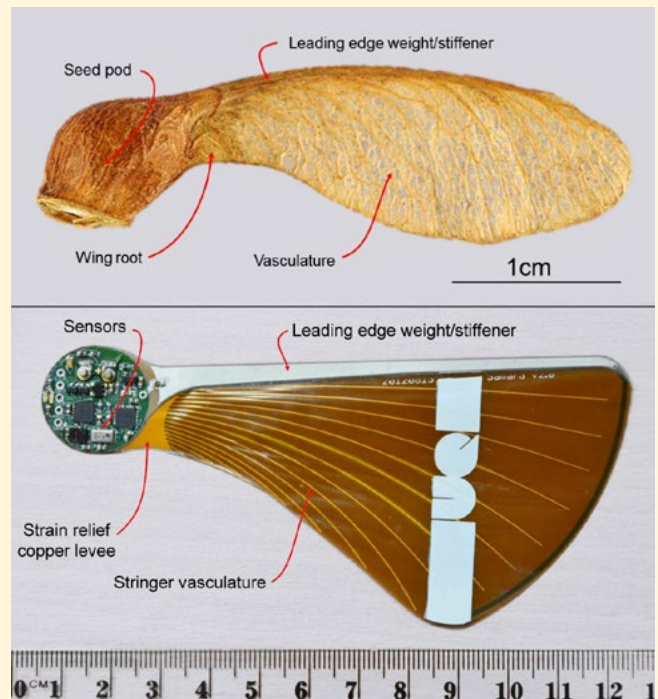

▲ Size comparison with UAV and samara seed  
(Source: © Dr Paul Pounds. Used with permission)

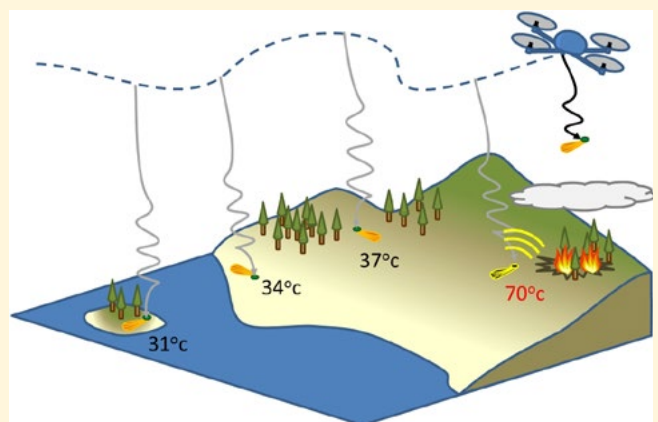

▲ Example of how the UAVs will be deployed  
(Source: ©Dr Paul Pounds. Used with permission)

## 4.2 Robot roundup

Just as section 4.1 explored what was happening in the world of drones, this section looks at examples of robots in research, exploration and industry.

### STUDENT ACTIVITY: ROBOTS

In this activity you will be investigating a current, existing use of a robot.

Your job is to research your chosen device and answer the following questions.

1. What is the purpose of your device and what problem does it solve?
2. Describe how the device makes a contribution to one or more of the following?
  - environmental problems
  - personal needs of people
  - community issues
3. Provide details on how the device is powered.
4. Describe how the operator and device communicate with each other.
5. How is the device controlled and/or programmed?
6. Who uses your chosen device?
7. Describe any issues that might be associated with the use of the device. Some possible issues you could discuss are safety, privacy, environmental damage, laws and legislation.
8. Evaluate your device by comparing and weighing up its benefits and limitations.
9. Propose possible modifications or improvements that would enable your chosen device be applied more widely and to a greater variety of circumstances?

### Robots: as effective underwater as on land

**Autonomous Underwater Vehicles** (AUVs) are unmanned, self-propelled robotic vehicles that may work autonomously for days or even months at a time. Although they are launched from a research ship, AUVs move about freely and are not attached to the vessel. When in action, they follow a pre-programmed course and do not require direct human control while collecting data.

AUVs have a wide range of applications and are increasingly being used for scientific, military and commercial purposes. Their ability to operate autonomously from a host vessel makes them well suited to exploration of extreme environments—from the world's deepest hydrothermal vents to beneath polar ice sheets. Existing AUVs can operate in water depths of up to 6,000 m, but it is predicted that this could almost double to 11,000 m in the near future.

In the last 15 years, AUVs have rapidly emerged as a vital tool for marine geoscientists, especially those involved in seafloor mapping and monitoring. The ability of these vehicles to fly at relatively low altitude over the seabed enables them to collect data at far higher resolution than surface vessels, especially in deep water. As well, they can be equipped with multiple payloads, including a high-resolution multibeam echosounder, sub-bottom profiler and sidescan sonar, a colour camera system, and Conductivity, Temperature, Depth and electrochemical redox (Eh) sensors.

### VIDEOS

To see an example of how robots are being used to collect oceanographic data view the video [Why are the oceans full of robots?](#) ABC Splash (5:04 min)

To see another example of how robotic systems are being used view the video [Ocean science robots](#), Ocean Today (2:07 min)



While advances in artificial intelligence will increase their reliability and flexibility, AUVs are already capable of making decisions that allow them to avoid seafloor or under-ice collisions. Increasingly, these vehicles are developed with sufficient intelligence that they can adapt their surveys according to changes in the environment they are monitoring. This feature was especially important when the Monterey Bay Aquarium Research Institute (MBARI) AUV was sent to study the Deepwater Horizon oil spill in the Gulf of Mexico, off the coast of the United States. Engineers were able to program the on-board computers to enable the AUV to find the oil plume and then map its boundaries, as well as to take water samples both within and outside the plume.

► [The autonomous underwater vehicle \(AUV\) Gulper being deployed on the RV Rachel Carson in 2012](#)  
[Source: ©Monterey Bay Aquarium Research Institute]

Not only did it measure physical characteristics of the water, such as temperature, salinity, and dissolved oxygen, detect chlorophyll from microscopic marine algae, and measure concentrations of oil droplets in the water, this particular AUV was unique in that it carried 'gulper' samplers that collected up to ten 1.8 L water samples while travelling through the water. After the AUV was recovered, these water samples were analysed for a variety of chemicals associated with the spilled oil and dispersants used to control it.

In contrast to AUVs, **Remotely Operated Vehicles**, or ROVs, are underwater robots that remain tethered to the host vessel where they have a human controller. The two are connected via an umbilical link that carries communications cables and provides energy. While this enables them to draw more power and communicate real-time data, their speed, mobility and spatial range are limited compared with an AUV.

ROVs can vary in size enormously and they perform functions ranging from simply carrying a camera to observe subsea environments to carrying out a huge variety of operational functions using multiple agile arms. These capabilities have ensured that the offshore oil and gas industry has come to rely on ROVs for drilling support and subsea construction services. This has enhanced deepwater exploration and development projects worldwide.

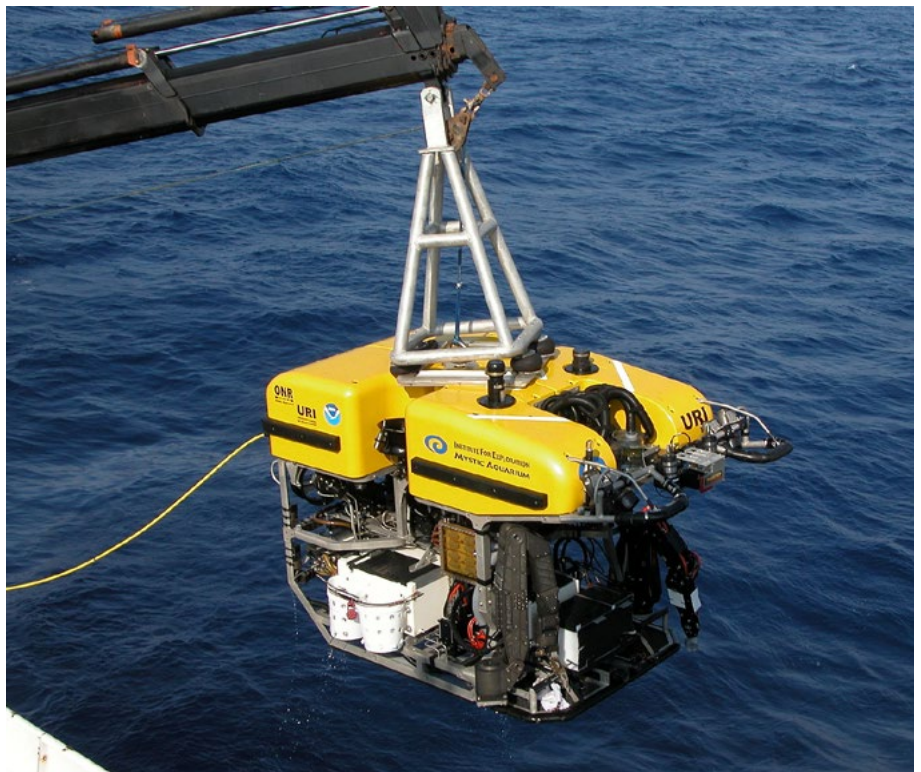

▲ [A science ROV 'Hercules' being retrieved by an oceanographic research vessel in 2005](#) [Source Wikipedia, Public Domain]

One of the amazing spin-offs from the widespread use of ROVs has been the SERPENT project. SERPENT stands for **S**cientific and **E**nvironmental **ROV** **P**artnership using **E**xisting **i**ndustrial **T**echnology, and is a worldwide collaboration between offshore oil and gas companies, their highly skilled ROV teams and one part of the world's scientific community, marine biologists.

This unique project shows the power of collaboration between scientists and industry partners. SERPENT is hosted by the National Oceanography Centre in the United Kingdom with a growing network of UK and global partners. However, it would not exist without the enthusiastic cooperation of the offshore oil and gas industry.

To learn more about the SERPENT project and check out the video galleries visit <http://www.serpentproject.com/>

### ACTIVITY

Middle primary students can build their own underwater robot. See [Roaming robots: Build your own underwater robot](#), Science Buddies.

### Eco-bots do the dirty, dull and dangerous work of environmental monitoring

In 2015, at Robotronica, Queensland University of Technology's annual open day dedicated to robotics, Dr Matthew Dunbabin, Principal Research Fellow, Autonomous Systems, in the Science and Engineering Faculty at QUT demonstrated a bright yellow Inference Robotic Boat. This boat illustrates one of the key features of robots: they can do jobs that are too dirty, dull or dangerous for humans.

In the past, information on natural waterways tended to be collected only in good weather as researchers did not venture out in cyclones, the dark, heavy rainfall and the like. Yet it is exactly at these times when environmental data is most important, as it may predict flooding, an oil spill or mud slide.

Dr Dunbabin's inference boats have been dubbed 'eco-bots' as they are fully autonomous floating sensors designed to be on natural waterways for months at a time. Here, they communicate via satellite to provide 24 hour real-time data on environmental conditions and threats. This makes environmental monitoring of our major waterways not only far more accurate and far more consistent but also safer for scientists.

Built from fibreglass, these streamlined robotic boats are 1.5 m X 1.5 m and sit low in the water to avoid buffeting by strong winds. Looking a bit like a solar car with solar panels and a camera system on board, they use differential steering and GPS to get around. Various sensors can be loaded on board to give researchers real-time environmental information on everything from salinity to pH to gas emissions. In addition, they can carry a water sampler that can collect 20 water samples at a time and bring them back to a designated spot.

These eco-bots have also been used to investigate dirty and dangerous environments like highly-polluted mine sites and even volcanoes.

The team from QUT has sent the eco-bots to collect water samples from a lake at a decommissioned mine site. No-one had been into the middle of the lake because the water was so acidic that a normal aluminium boat would corrode and disintegrate in the toxic sludge. On a recent excursion to the Solomon Islands, the team successfully tested underwater volcanoes with this new robot. 'We've got some of the first data sets where we've mapped the topology and methane and carbon dioxide release from active subsea volcanoes,' Dunbabin said. (See [The world's rivers and oceans will soon be full of robots](#), 24 August 2015, MashableAustralia.)

Scientists are also using drones and robots to help them understand more about Antarctic ice.

### VIDEO

To see how the use of these technologies is not only safer but much faster and more efficient view the video [New tools to explore the frozen frontier](#), ABC Splash (1:26 min)

### Pipeline PIGs: keeping pipes squeaky clean

What have flames shooting two football fields high into the night sky, a fire sounding like four roaring jet engines and a week enduring cold showers in the mid north of South Australia have in common? All these recent events resulted from the rupture of pipelines carrying gas or petroleum products. Such disasters can also disrupt industry and businesses and cause significant pollution of the local environment and nearby towns.

The rupture of the Moomba-Adelaide pipeline in 2015 was caused by stress corrosion cracking, a form of corrosion brought about by the combined influence of stresses, crack defects on the pipeline wall and a corrosive environment. All over the world, pipelines are used to carry gas and oil thousands of kilometres because they are much more energy efficient than transportation by train or by truck. So how can damage to pipelines be detected and repaired to avoid dangerous ruptures in the future?

Scientists have developed highly sophisticated instruments to inspect, safety test and carry out maintenance operations on pipelines. They are cylinder shaped, one or two metres long, weighing up to two tonnes and are called 'Pipeline PIGs'. PIG is an acronym for **P**ipeline **I**nspection **G**auge or Pipeline Intervention Gadget, but some people say these tools are called pigs because of the squealing sound they make when they travel through pipes.

Some PIGs move in only one direction, carried by the pressure that moves the gas or oil swiftly through the pipe. Others are capable of reversing in the pipeline so that they can be launched from and returned to a single location.

Some PIGs are used just for cleaning the pipeline, but the most interesting ones, called Smart PIGs, are equipped with highly tuned sensors. The technology used varies according to the service required and the design of the pig, but invariably, non-destructive technologies are used.



▼ [Pipeline pig](#) (Source: Wikipedia, Harvey Barrison, [CC BY SA 2.0](#))

For example, calliper PIGs measure the roundness of pipes to determine areas of crushing or other deformations. Other sensors measure the thickness of the pipes they are travelling through to detect cracks, fissures, corrosion and other problems that may affect the integrity of the pipeline. Alternatively, an ultrasonic testing (UT) inspection PIG uses ultrasound to detect changes in the thickness of the pipe wall.

Data from the PIG is not transmitted in real-time. The combination of thick steel and being underground or underwater most of the time does not allow for communication while in operation. Instead, data collected by odometers, gyroscope-assisted tilt sensors and other technologies is interpreted after a successful smart PIG launch and retrieval.

The PIG's internal record can provide an exact location after it is compared with data from surface sensors that record the pig's passage through the pipeline. These external instruments measure either sound, magnetism or radio-transmission from the passing pig and have GPS capability to transmit the PIG's passage, time and location via satellite uplink. The PIG itself cannot use GPS as the metal pipe blocks satellite signals.

The combined data reveals the location, type and size of each pipe defect. If the damage is severe, this information is used by repair crews to locate the defect quickly without having to dig up excessive amounts of pipeline. Repeated runs by smart PIGs over a period of time can be used to evaluate the rate of change of a particular defect over several years, enabling proactive planning to repair the pipeline before any leakage or environmental damage occurs.

### Robots enter the world of animals

Scientists can send robots into the animal world to see what is going on. But what if they can take the robot animal interaction a step further so that the robots live and communicate with the animals?

Adélie penguins have been breeding for hundreds of years on the West Antarctic Peninsula. This area has recently become one of the most rapidly warming areas on Earth. A worrying decline in Adélie penguin numbers from 15,000 breeding pairs to only a few thousand pairs has prompted researchers to enlist the help of a robotic autonomous underwater vehicle called REMUS, to deep sea dive with the penguins.

The scientists used the robot to test a hypothesis that the population decline was due to feeding competition with another species of penguins—gentoos—that have moved into the area only in the last 20 years. As both species eat krill, scientists were asking, "Are the two species eating out of the same lunch box"?

First of all, the scientists tagged penguins with small satellite transmitters and depth recorders to track where they went to gather food for their chicks and how deep they were diving. Each penguin parent completed a few foraging trips and up to thousands of dives while tagged.

Next, the research team used REMUS to sample the water where the penguins were foraging, something few researchers have done before. The REMUS provided important measurements on temperature, salinity and the light intensity, as well as the amount of phytoplankton and krill present in the water. This allowed the researchers to examine each step of the food chain from phytoplankton to krill to penguins.

A novel aspect of the study was that the environmental sampling done by the robot was informed by the location of the penguins. Without the REMUS—which can swim at about the same speed and dive almost as deep as a penguin—the researchers would not have known what was going on in the waters where the penguins were swimming. In this way, scientists could couple the behaviour of these two species with the distribution of their prey and make distinctions that were not possible beforehand.

An analysis of the data on thousands of foraging dives revealed that the Adélie and gentoo penguins rarely competed for food because they tended to forage in different areas. Occasionally, when there was a small area of overlap between the two populations, the gentoos tended to shift their behaviour and forage at deeper depths.

With this conclusion, the study was able to propose a new hypothesis that Adélie declines along the West Antarctic Peninsula are due both directly and indirectly to the impact of climate change. (See Roberts, Karen B [Penguins and robots](#), 7 January 2016, UDaily, University of Delaware.)

But what if scientists can take the robot animal interaction a step further?

Associate Professor Thomas Schmickl from the Artificial Life Lab at the University of Graz in Austria is developing tiny robots to eventually live in a hive with the bees and commune with them.

His preliminary work involves removing bees from the hive and placing them with the robots in particular situations in the laboratory. There, he films and studies them to see how the robots and the bees react how they might co-habitate and merge into a single society.

Ultimately he wants to develop a robot bee that can live in a hive and exert influence over the real bees. For example, based on the weather forecast, the bee bots could tell the bees it is a good time to reproduce. His aim is to boost the number of bees in a hive, as an increased population causes the bees to split their colony into two. As bees are important pollinators of our crops, generating more bee colonies in this way will be good for agriculture. (See [Robotic agriculture and swarming with bees](#), 22 November 2015, *Future Tense*, ABC Radio National.)



▲ Two Adélie and two gentoo penguins (Source: ©Dmytro Pylypenko/123rf)

**Robots in agriculture: the farm of the future is nearer than you might think**

The Australian Centre for Field Robotics (ACFR) in the University of Sydney has developed a variety of robots each with particular characteristics that make them suitable for certain tasks. They are called 'Ladybird', 'Shrimp' and 'Mantis'. (See ['Our Robots'](#), ACFR, University of Sydney.)

The Ladybird is a solar powered electric vehicle that can drive autonomously up and down rows of a vegetable farm. The most impressive use of the Ladybird has been in weed detection and spraying. Its cameras, that can detect a variety of multispectral images, have an amazing 1 mm resolution, meaning that essentially, a single leaf can be mapped in 3D. This allows the Ladybird to recognise the difference between a crop plant and a weed.

When the Ladybird detects a weed seedling it can fire a small and controllable volume of spray directly at the target. This technology is so accurate that it can be used to deliver tiny amounts of herbicide exactly where it is needed. Compared with conventional blanket spraying, Ladybird reduces herbicide usage by over 99 per cent. Future modifications could allow the Ladybird to either pull out the weed, or even laser it or microwave it. Minimising the use of herbicide not only reduces costs, but it is better for the environment.

**VIDEO**

[Ladybird: real-time targeted spot spray](#), YouTube (3:34 min)

The ACFR have also been working on Perception Research Ground Vehicles. Robots have been called Mantis and Shrimp because the mantis shrimp has amazing sensory perception capabilities, and indeed that is a key feature of these two robots. Like the Ladybird, the Mantis and the Shrimp use a number of different multispectral sensors that span across the electromagnetic spectrum, from the visible light, that we humans see, through to thermal wavelengths. They navigate by using a forward looking LiDAR sensor to build 3D pictures of the world around them.

The Shrimp has been successfully used to herd groups of 20 to 150 dairy cows with no instrumentation on the cows. The cows displayed no alarm with the robot amongst them and they were gently herded into the dairy. In fact the slower pace has positive health benefits for the cows, as rapid movement can lead to lameness. (See ['A robot amongst the herd'](#), ACFR, University of Sydney.)

**VIDEO**

To see a video of the Shrimp herding cattle go to [A robot amongst the herd](#), ACFR, University of Sydney (2:08 min)

**Inspiration from nature: useful robots made by mimicking insects.**

Insects like ants and cockroaches may disrupt our lives and be annoying, but now scientists are using them as models to build useful robots. This bio-mimicry, as it is called, requires an in-depth study of the insect, followed by creative design and miniaturisation.

Kaushik Jayaram and Robert Full from the University of California, Berkeley decided that the ability of cockroaches to modify their body shape and move quickly through tiny cracks and crevices could be copied to produce a search-and-rescue robot.

Using a high-speed camera, Jayaram filmed cockroaches squeezing through narrow slits and running between plates at various spacings. He found that by compressing their bodies' compliant exoskeletons, cockroaches that usually stand at a height of 12 mm can run at speeds of 20 body lengths per second, through spaces as low as 4 mm. As well as being fast and flexible, in an amazing show of strength, cockroaches can withstand pressure equivalent to 900 times their body weight without injury.

Inspired by this knowledge, the researchers built a simple and cheap robot they called CRAM - Compressible Robot with Articulated Mechanisms. Its shell-like casing, made of overlapping polyester plates, makes it 75 mm tall and its legs are very flexible. These features enabled it to squeeze into and run through crevices half its height and bear a load of around a kilogram, which is 20 times its own weight. (See [Cockroach inspires robot that squeezes through cracks](#), 8 February 2016, Berkeley News, UC Berkeley.)

**VIDEO**

Watch a video on UC Berkeley's research: [Cockroach robots to the rescue](#), YouTube (2:06)

The researchers are convinced that they have made a prototype search-and-rescue robot that can look for survivors by rapidly squeezing through rubble resulting from tornados, earthquakes and explosions.

A single 5 mg ant can hold an impressive 500 mg, which is 100 times its own weight. But when a swarm of ants make strong chains by grabbing onto each other, they can move even bigger objects like huge food items.

Inspired by nature, micro-robot engineers at Stanford University's Biomimetics and Dexterous Manipulation Lab asked "Can our robots work together to accomplish great things?" Their aim was reverse the current trend in which small robots have become better at moving and sensing, but is unable to change the world by moving human-scale loads.

When the researchers considered the dynamics of teams, not just individual microbots, they found that the interaction between the robot and the ground is critical to the size of the forces they can generate.

If a microrobot ran or moved with short, jerky jolts the total force only increased a little with a team. When the scientists focused on synchronizing the smooth application of a very long, very slow, very steady winching gait, they were able to show that a team of six MicroTugs ( $\mu$ Tugs) weighing just 100 g in total, could pull a car weighing 1,800 kg. (See '[Microtugs](#)', Stanford University website)

**VIDEOS**

Watch videos of Stanford University's Biomimetics and Dexterous Manipulation Lab research on microbots:

[MicroTug mighty micro robot simply explained](#), YouTube (2:29 min). Includes cartoons and animations, its less research video and more friendly.

[Let's all pull together: team of  \$\mu\$ Tug microbots pulls a car](#), YouTube (1:44 min)

[\$\mu\$ Tug: Micro robot pulls 2000 times it weight on glass](#), YouTube (2:10)

This work demonstrates a new type of small robot that can apply orders of magnitude more force than it weighs. It is hoped that when scaled up, the technology behind the robots can be put to use hauling heavy objects in factories or construction sites. Another possibility is in emergency scenarios, where heavy debris could be moved from collapsed structures to free survivors.

One day in the future, once a cockroach-inspired robot has located survivors at the scene of an earthquake, teams of ant-like robots could pull aside slabs of debris to allow rescuers to access the injured. Bio-mimicry could ensure that annoying insects become a powerful inspiration in design and technology.



▲ The compressible robot, CRAM with a complaint, yet tough cockroach. †[Source: ©Tom Libby, Kaushik Jayaram and Pauline Jennings. Courtesy of PolyPEDAL Lab UC Berkeley.]

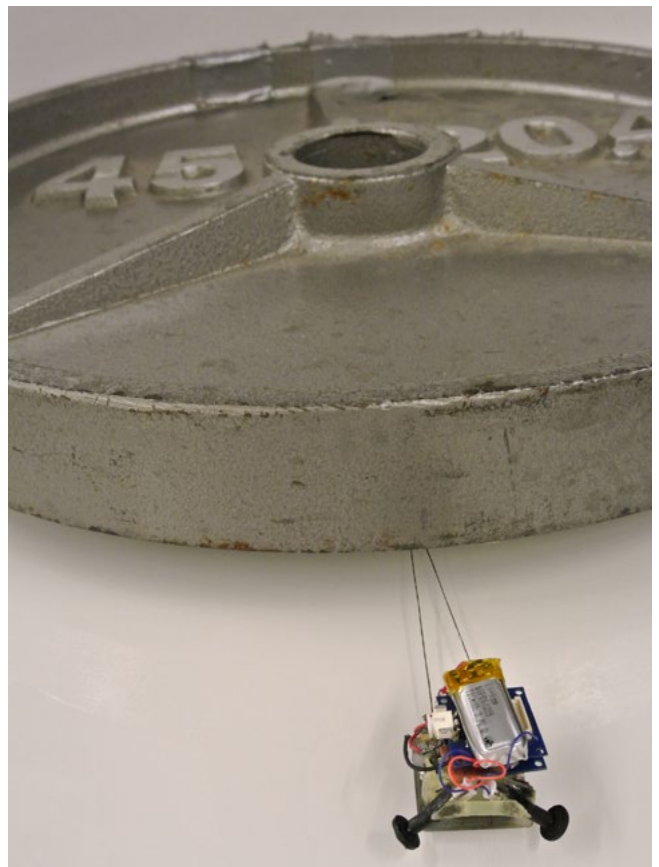

▲ Microtug. [Source: ©Karen Ladenheim. Biomimetics and Dexterous Manipulation Lab, Stanford University]

**VIDEO**

To learn more about this type of robot view the video [Biomimicry robots](#), ABC Splash (3:38 min)

**Industrial robots**

Robots are used extensively in industry where they perform repetitive manual tasks with precision and accuracy.

In one example, five large, fixed robots quickly and efficiently assemble cooker doors and add them to the production line in a whitegoods factory. The advantages are a reliable system that makes a consistent product, with an increase in safety for workers.

**VIDEO**

To see how Electrolux in Adelaide are using ABB robots to manufacture doors view the video [ABB Robotics – Cooker door assembly line](#), YouTube (5:52 min)

Similarly, one of the busiest shipping terminals in the United States, TraPac LLC's Los Angeles, has just begun using more than twenty-four giant red robots to move cargo containers along the docks with minimal human intervention. The new system will significantly reduce the amount of time a ship spends in port, while improving productivity by as much as 30 per cent. (See '[Massive robots keep docks shipshape](#)', 27 March 2016, The Wall Street journal.)

Not all industrial robots are large powerful machines. In a family-run bakery in Valencia Italy, the FlexPicker™ packages delicate chocolate and cream-filled puff pastry rolls, known as *napolitanas*, at a rate of 400 units per minute. The design of the robot enables it to handle the pastries as gently as a human would and, at the same time, is adaptable enough to carry out several packaging tasks simultaneously. (See '[Packaging a piece of cake](#)', 8 September 2008, ABB.)

**VIDEO**

See how the FlexPicker™ deals with pancakes on a factory conveyor belt in [High speed pancake stacking with FlexPicker robots](#), YouTube (0:59 min)

Apart from the increased productivity, people no longer have to do unpleasant, fiddly jobs so fewer sick days are taken now. In addition, quality control is made easier and hygiene improved, as human hands do not touch the products.

**RoboCup — Kicking Goals for Artificial Intelligence**

[Robocup](#) is an international research and education initiative that aims 'to promote robotics and AI research by offering a publically appealing, but formidable challenge'. Its goal is to foster artificial intelligence and robotics research by providing a standard problem (playing soccer) where a wide range of technologies and concepts can be integrated and examined in comparison to other teams.

The ultimate goal is to have a team of fully autonomous humanoid robots win a soccer game against the winners of the FIFA World Cup—all by the middle of the 21st century. However, the more modest goal has been identified as the robot team playing like human players.

**RoboCup also includes:**

- [RoboCup Junior](#) — a project oriented educational initiative emphasising both cooperation and competition. (See Chapter 7 for more information)
- RoboCup Rescue — promoting research and development of robotic systems to aid in disaster rescue.

RoboCup, together with RoboCup Jr, counts as one of the most significant events of its kind. Every year it involves about 3,000 people from about 40 countries and a world-wide support of over 100,000 people.

Two universities in NSW—University of Newcastle and the University of NSW—compete in RoboCup. See their stories below.

## Australian Research

The University's of Newcastle's NUbots team develops software for autonomous robotic soccer and competes every year in the international RoboCup competition. They won the world title in 2006 and 2008.

Supported by world-leading embedded computing technology company, Kontron, the NUbots team is mainly formed by Computer Science, Software Engineering and Computer Engineering students, at various levels (undergraduate, masters and PhD), as well as several academics.

In addition to robotic soccer, the NUbots team is also investing its time in other technologies, such as virtual reality and telepresence, aiming at robots that can assist humans in doing physically demanding tasks, or tasks that are simply too dangerous for the average human.

All the work developed by the team is in reality a testing bed for ground-breaking artificial intelligence and intelligent robotics research. The NUbots team's research vision is to develop and program robots that can support humans, with a focus at the responsible and ethical development and application of robotics.

Learn more about the NUbots at [Newcastle's Robotics Laboratory: NuBots](#) page.

### VIDEO

Watch the University of Newcastle RoboCup team compete in the qualification round in 2014: [NUbots RobCup Kid-size Qualification Video 2014](#), YouTube (3:26 min)

(Source of images: ©Newcastle University Robotics Laboratory. With permission)

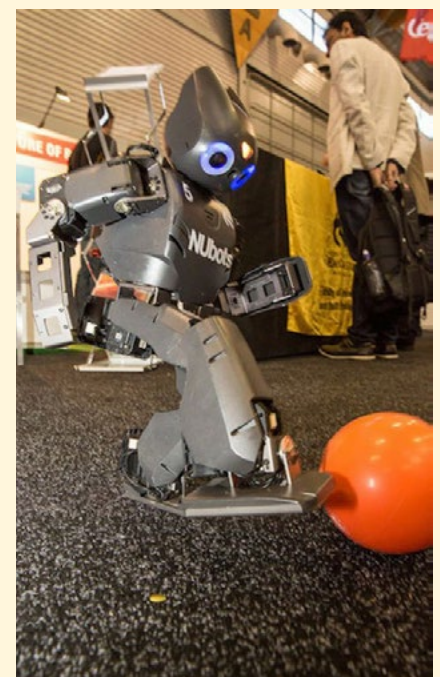



The [School of Computer Science and Engineering \[CSE\]](#) at the University of NSW (UNSW) has strengths in robotic soccer where they are currently world champions in the international RoboCup Standard Platform League for the past two years.

### VIDEO

To see footage of the 2015 RoboCup final where UNSW were the victors see [2015 RoboCup SPL Grand Final – UNSW vs B-Human](#), YouTube (23:48 min)



### ARTICLE

Harris, Shaun. [How we won the world robot soccer championship](#), 6 August 2016, The Conversation.

This research aims to accelerate the development of robotic technologies and much of the work can be translated into other fields and applications. CSE researchers have also developed urban search and rescue robots, winning several international awards at the RoboCup Rescue competition.

Another area of interest is in human-robot collaboration. This work is also being conducted in collaboration with the [Creative Robotics Lab \[CRL\]](#) at UNSW. CRL, part of the National Institute for Experimental Arts, is a cross-disciplinary research environment committed to examining human interactions with three-dimensional robotic agents and responsive structures within the context of experimental arts and social robotics. The lab researches experimental human-robot interfaces and studies human-robot interaction in physical spaces.

CSE provides robotics workshops for school students and teachers. More information can be found at [Robotics Workshops](#), School of Computer Science and Engineering, UNSW.

▼ The UNSW RoboCup team (Source: ©Bradley Hall, UNSW. With permission)

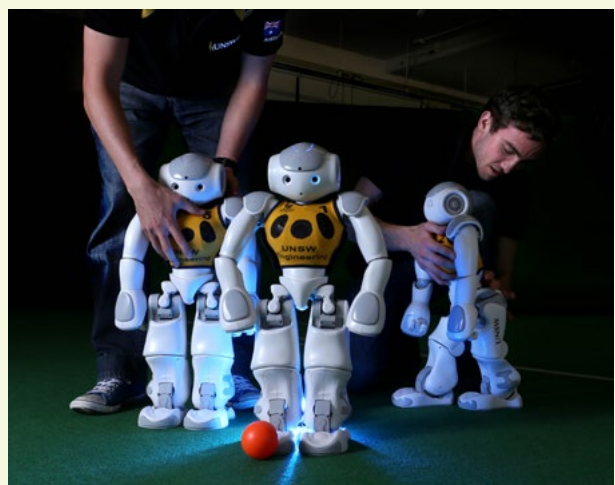

### 4.3 Making life easier with robots

In many older science fiction scenarios, androids and robots were featured as household servants who did the drudgery their human masters didn't want to do themselves. Their job was to make life easier for their human masters. For example, in the 1999 movie, *Bicentennial Man*, Andrew was a robot butler that strove to be recognised as a human being, while in the 2013 movie, [Robot and Frank](#), Robby is a carer for an elderly man. The development of robotic devices which make our lives easier, has long since moved from the realm of science fiction into everyday devices, many of which are found in today's homes.

In this section examples of devices that are making our life easier will be explored.

#### Who is driving driverless cars?

While companies like Google, Mercedes-Benz and Tesla have been testing self-driving vehicles across the world, in November 2015 Volvo was the first company to introduce driverless cars to Australian roads. As it drove along Adelaide's Southern Expressway, the Volvo XC90s used adaptive cruise control and pilot assist functions to keep in between lanes and avoid front-end collisions. Since then, the South Australian government has shown how serious they are by passing laws to allow trials of automated vehicle technology on public roads in that state. (see Tucker, Harry. [Volvo will be the first car company with a driverless car on Aussie roads](#), 21 July 2015, News.com.au)

#### VIDEO

To see the Google self-driving car view the video at [Google self-driving car project](#), Google.com

Australian mining giant Rio Tinto just completed its rollout of huge driverless trucks to transport iron ore and other material around its Pilbara mine sites. Employees in a control centre in Perth, 1,200 km away, control the trucks so strictly speaking they are not really 'driverless' but the safety and economic implications are compelling. Trucks can operate 24 hours a day, 7 days a week, all year round and without a driver who needs to take breaks, this autonomous technology save up to 500 work hours per truck per year. Rio Tinto isn't the only mining company employing autonomous vehicles. BHP Billiton and Fortescue have also been testing the new technology. (See Diss, Kathryn. ['Driverless trucks move all iron ore at Rio Tinto's Pilbara mines, in a world's first'](#), 19 October 2015, ABC News.)

The goal of those developing driverless cars is *fully* autonomous vehicles that completely take humans out of the driving seat.



◀ Autonomous Haulage System trucks at the West Angelas mine, WA [Source: [M2M](#)]

## Australian Research

### Large-scale field vehicles (mining and agriculture)

Researchers in Robotics and Autonomous Systems in the School of Mechanical and Manufacturing Engineering (MME) at the University of NSW (UNSW) have developed expertise in the area of large-scale field vehicle guidance. They have developed fully autonomous technologies that have been commercialised.

The developed systems can be viewed at [www.robotics.unsw.edu.au](http://www.robotics.unsw.edu.au).

The commercial versions of the applications can be seen at [www.aurotron.com](http://www.aurotron.com) or [facebook.com/Aurotron](https://facebook.com/Aurotron).

Based on the success of the field machinery automation, Komatsu Japan has begun developing a partnership with UNSW-MME to develop autonomous bulldozers for applications in mining, which is commonly known as 'bulk push'. A Komatsu bulldozer has arrived at the field station of UNSW-MME and the autonomous operation will be demonstrated in July 2016.



► Autonomous bulldozer (Source: © Jay Katupitiya, UNSW. Used with permission)



◀ Autonomous seeder for broad acre crops (Source: ©Vincenzo Carnevale, UNSW. Used with permission)

Driverless vehicles use a variety of sensors to detect the physical environment they are moving through. An example is seen in Google cars that have the following advanced, state-of-the-art sensors:

- Radar is used for adaptive cruise control as reflected microwaves can identify the location and speed of nearby vehicles.
- A video camera, attached to the driver console, checks for stoplights, bikers, and pedestrians.
- On the left wheel of the car there is a position estimator that detects the revolutions per minute (RPM) of the car. This gives its speed and, along with the global positioning system (GPS) unit, helps determine an accurate position of the car.
- Ultrasound aids parking as the reflected sound waves can detect the distance to nearby objects.

### VIDEO

To see how driverless cars actually see the road, view the video '[Chris Urmson: How a driverless car sees the road](#)', YouTube (15:29 min).

The eyes of self-driving cars are a Light Detection and Ranging technology called a LIDAR. This sensor, based on light and radar, gives a 360° view to the driver and is used to create a detailed 3D map of the surrounding environment in order to view all obstacles in real time. LIDAR, also written Lidar, LiDAR or LADAR, is a surveying technology that illuminates a target with laser light, measures the time for the signal to return, then uses radar's ability to calculate the distance to the object.

Software adds information from other sensors to the LIDAR data and, after comparing the resulting map with existing maps, alerts the system of any differences. This means that very detailed maps of the roads and terrain is essential to determine accurately where the car actually is. This will have the effect of limiting the areas in which driverless cars can initially be driven. Mapping an urban area alone is a much smaller problem than mapping a whole state or the whole country.

► **Automobile sensors used in self-driving cars:** camera data with pictures Radar and LIDAR Autonomous Driverless Car (Source: ©Oodoroaga Monica/123rf)

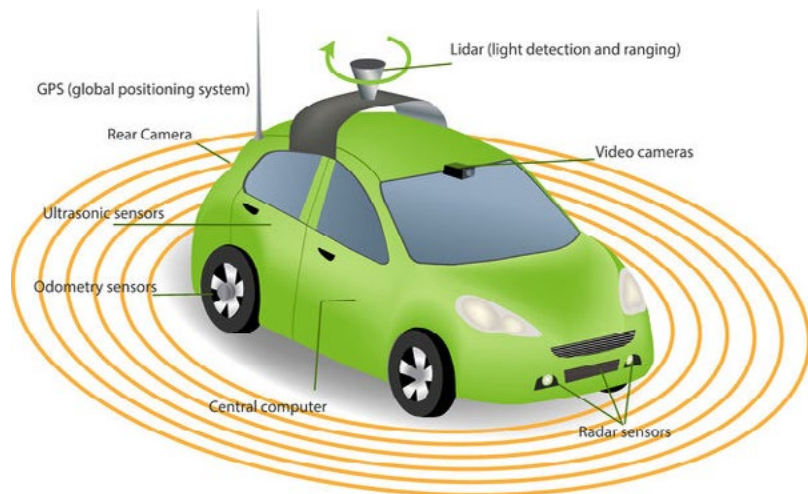

### VIDEO

To learn more about how LIDAR works and different uses of the system view the video '[How does LiDAR Remote sensing work? Light Detection and Ranging](#)', YouTube (7:44 min)

In order to self-drive, a vehicle must process many gigabytes of data from its sensors in real time, generating a map for planning the route to any given destination. It then translates all this data into commands to control the vehicle, while avoiding obstacles such as other cars and obeying traffic signals, local traffic laws and rules of the road.

Driverless cars need to be able to cope with almost every situation which they might encounter. They must correctly detect and categorise objects in many situations, for example a child on the side of the road, but they also need to anticipate their behavior, possibly running out in front of the car.

Self-driving vehicles are not programmed in the classical sense, instead they rely on machine learning and pattern recognition, which have been developed in the field of artificial intelligence. Just as humans learn from examples, driverless cars need to learn from data to cope with dynamic, real-world traffic. Their behaviour can be seen as being the result of a long and varied program of learning from experience.

The potential is for self-driving taxis and buses to change the nature of urban mobility. They will also be electric, meaning less pollution will be generated. More short-distance travel in small, lightweight, extremely energy efficient self-driving taxis is likely to occur. Another big advance will be for people not to own a car at all, but to instead use a mobile phone to summons one when needed. Ride-sharing, especially during peak hours and on certain routes, is also likely to be more common. It has been estimated by researchers that each self-driving taxi may replace six to ten privately owned vehicles.

Current research aims to establish not only ways of controlling driverless cars but to develop the systems through which they can share the roads. The development of vehicular communication systems will allow autonomous vehicles to communicate their position, speed and the condition of traffic around them to other cars and traffic control centres. Collaboration achieved in this way could contribute to improving traffic flow and even make traffic lights and road signs unnecessary.

These same networked capabilities could also enable cars to foresee potential collisions and take steps to avoid an accident. In addition, some 40 per cent of accidents are caused by reduced visibility like poor lighting or bad weather conditions and more than 70 per cent are the result of human error like speeding, loss of concentration, frustration, fatigue and driving under the influence of alcohol or drugs. One industry report has estimated wide-scale introduction of driverless cars could reduce accidents by up to 90 per cent.

Some of the issues associated with driverless cars come about because the systems will rely so heavily on computer technology, making them vulnerable to malicious attack and malfunction. Small errors in the design or operation of the software could lead to collisions or other occurrences that could have fatal results. That the cars are also likely to be directly networked to other vehicles and to control systems will mean that each car will collect huge quantities of data about its surroundings, including the locations of other vehicles and road users. Many people will be concerned about the privacy implications of the collection and storage of data of this kind.

Vehicles that drive themselves with no human assistance are probably much closer than many think—perhaps less than ten years away.

### Helping at home

#### ■ Cleaning devices — responding to their environment

Some robotic devices work by responding to their environment. Take for example, the iRobot® Roomba® Vacuum Cleaning Robot which is able to change direction on encountering obstacles, detect dirty spots on the floor, and sense steep drops to keep it from falling down stairs. The newest models have a self-charging homebase that the Roomba searches for at the end of a cleaning session using infrared beacons.

Roombas do not map out the rooms they are cleaning. Instead, the iRobot® company developed a system called iAdapt Responsive Cleaning Technology. This design is based on the philosophy that robots should be like insects, equipped with simple control mechanisms tuned to their environments. The result is that although Roombas are effective at cleaning rooms, they take several times longer to do the job than a person would. The Roomba® may cover some areas many times and other areas only once or twice.

#### ► [The path taken by a Roomba vacuum cleaner as it cleans a room](#)

[Source: Chris Bartle, Wikimedia Commons, [CC BY 2.0](#)]

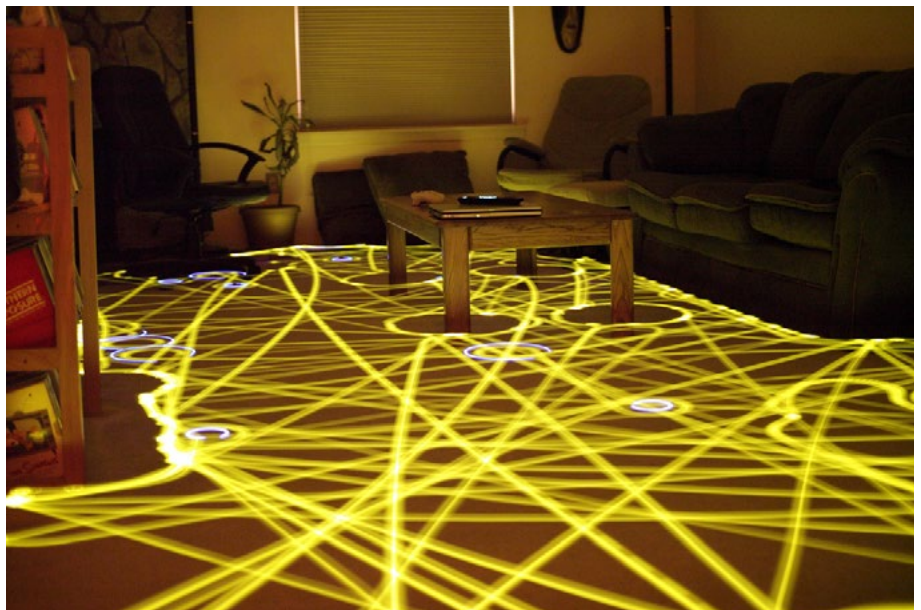

Another responsive robot is the [Litter-Robot™ III Open Air](#). This automatic self-cleaning litter box for cats has a self-adjusting weight sensor that can detect both small and larger cats. The litter is automatically cleaned after each use and waste is deposited into a convenient drawer. Features include an indicator when the drawer is full and an automatic night light for elderly cats.

#### VIDEO

Take a look at how the Litter-Robot works in this video '[Litter-Robot Open Air](#)', YouTube (1:30 min)

#### ■ Segway's Robotic Butler

Many of the latest robots displayed at the huge Consumer Electronics Show (CES) which 'swamps' Las Vegas each year are designed to make life easier for people.

Take for example, the Personal Transportation Robot, a joint creation by Ninebot and Segway. At first glance, it looks like one of Segway's earlier self-balancing scooters, with two wheels supporting a standing platform. But when a person steps off its platform and presses a button, a head emerges and the machine becomes a robot that uses Google Android software and Intel RealSense technology.

The head contains five cameras and one laser projector for tracking its owner and capturing high-resolution photos and video on demand. These multiple cameras, together with sensors, support the Track and Follow mode that enables the robot follow its master once they have disembarked. A sensitive microphone and voice recognition software allows it to pick up and understand voice commands. The arms are easy to attach and allow the robot to carry objects. As the robot is capable of connecting with other smart hardware, it could also be used to control household devices like lights, air conditioners and televisions.

The company describes the machine as "a Segway that sees the world and a robot that gives you a ride", but, it is more commonly called a robotic butler. With its ability to assist transport, carry objects and obey voice commands, it is tipped to be particularly useful for the elderly or incapacitated. The development program plans to have real-world user testing at the end of 2016. (see <http://robot.segway.com>)

#### VIDEO

To see the robotic butler and what it can do view the video '[Ninebot Segway Robot Launch at CES 2016](#)', YouTube (4:56 min)

#### ■ Socially assistive robots

Socially assistive robotics (SAR) is a new field of intelligent robotics that focuses on developing machines capable of assisting users through social rather than physical interaction.

This field of robotics aims to develop robots capable of monitoring and motivating, people's activities, in order to improve human learning, performance and health outcomes. Robots of this type are being developed as companions for the elderly, to help accident and stroke survivors to regain physical movement and for one-to-one peer learning in the classroom.

#### VIDEO

To see how two robots are being used with elderly people view the video [Friendly robots](#), ABC Splash (1:23 min)

#### *Tega the tutor*

Researchers from Tel Aviv University, in Israel, and the Massachusetts Institute of Technology (MIT) have developed a socially assistive robot called 'Tega'. The robot uses an Android device to process movement, perception, and thinking, and responds appropriately to behaviours. A second Android phone contains software that enables Tega to interpret the emotional content of facial expressions, a method known as affective computing.

The researchers piloted the robotic system with 38 students aged three to five years old, in a preschool in Boston in the United States. The students were divided into two groups—a control group and an experimental group. The students in the trial learned Spanish vocabulary from a tablet computer loaded with a custom-made learning game. Each student worked individually with the furry and brightly coloured robot, Tega, for 15 minutes per session over the course of eight weeks.

In the control group Tega mirrored the emotional response of students by getting excited when they were excited and distracted when the students lost focus.

For the experimental group, Tega interpreted the emotional response of the student it was working with and, based on those cues, created a personalized motivational strategy. It then tracked the impact of each of these cues on the student. Over time, once Tega learned how the cues influenced a student's engagement, happiness and learning success, it began to personalize its responses in a way that would optimize each student's experience and achievement.

The researchers found that the children receiving personalised help from Tega (the experimental group) were more engaged by the activity. They also found that some of Tega's reactions, like a yawn or a sad face, had the effect of lowering the engagement or happiness of the student.

As well as showing that personalized assistive robots are effective in a real classroom, the researchers found that the system was thoroughly embraced by both the students and the teachers. As the robot is almost entirely wireless driven and easily set up and operated behind a divider in an active classroom, they also showed it to be a practical system that did not disrupt the rest of the class. (See [Tega](#), Personal Robots Group, MIT.)

## VIDEO

'[Tega: A Social Robot](#)', YouTube (1:56 min)

## Pepper

[Pepper](#), Héctor García, Flickr, [CC BY-NC-SA 2.0](#) ▶

Pepper is a warm, kind and likeable humanoid robot that moves around autonomously and can speak multiple languages. As it has been designed to communicate with people in a natural and intuitive way, through body movements and voice, it is classed as a socially assistive robotic.

Pepper is capable of recognising the principal human emotions based on tone of voice, facial expression, body movements and words used. It then adapts its behaviour to best suit to the situation.

Pepper's mobility and exceptional flexibility—it can shake hands and hug the person it is talking to—comes from its clever design. The robot's head has four microphones, two HD cameras (in the mouth and forehead), and a 3D depth sensor behind the eyes. There is a gyroscope in the torso and touch sensors in the head and hands. The mobile base has two sonars, six lasers, three bumper sensors, and a gyroscope.

More than 140 SoftBank mobile phone stores in Japan are using Pepper to welcome, inform and amuse their customers. One store in Tokyo is staffed entirely by five or six robots. They help customers by recommending the best phone to buy, then handling the ordering. Pepper has a cloud-based artificial intelligence system allows it to respond appropriately to customers queries and requests in real time. Although a couple of human staff members will be nearby, customers will be able to order a mobile without their help.

The idea behind the collaboration between the makers, Aldebaran Robotics, and SoftBank is that customer feedback will inform improvements and modifications in Pepper's next model, which will be sold as a domestic companion for families. Already Pepper sings, dances and chats to the elderly residents at the Shintomi aged care home in Japan. (See [Cool Robots: Who is Pepper?](#), Softbank Robotics.)

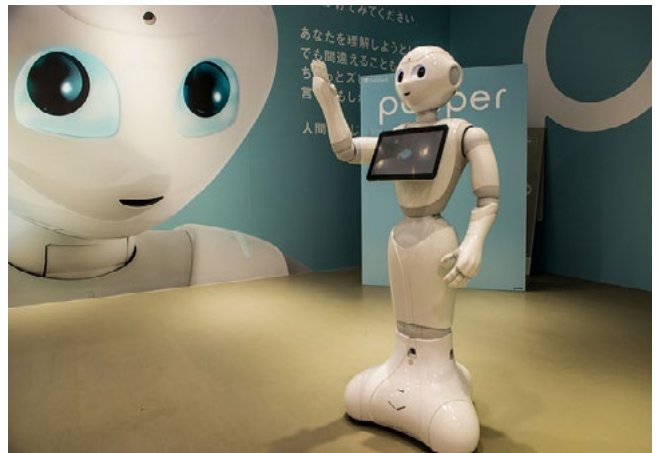

**VIDEOS**

Watch the following interview with Pepper, which demonstrates why it will integrate easily into either the home or consumer space. '[Robot Pepper performance September 2015. Hugs with Pepper](#)', YouTube (4:14 min)

To see another example of using a robot to help with training view the video '[What is a joggobot?](#)', ABC Splash (3:44 min)

**Aggie**

Aggie is the world's first art gallery engagement robot, right here in Australia, at the Art Gallery of Western Australia (AGWA) in Perth. She is an engaging, humanoid robot that stands 58 cm tall and she will join her human colleagues to lead monthly, gallery tours for visitors, particularly families. She will also host art classes for children. Not only can Aggie be programmed with detailed information on the gallery's artworks, she can also sing and dance and create soundscapes.

Aggie is a Nao robot, designed by a French company with software developed by a Belgian company and 'fine tuned' by a local Perth robotic technology company.

Aggie is powered by a rechargeable battery and equipped with:

- 2 high definition cameras
- 2 lateral loudspeakers
- 4 directional microphones
- Sonars (2 emitting and 2 receiving)
- Linux operating system

(See [Aggie — the world's first art gallery engagement robot](#), Art Gallery WA)

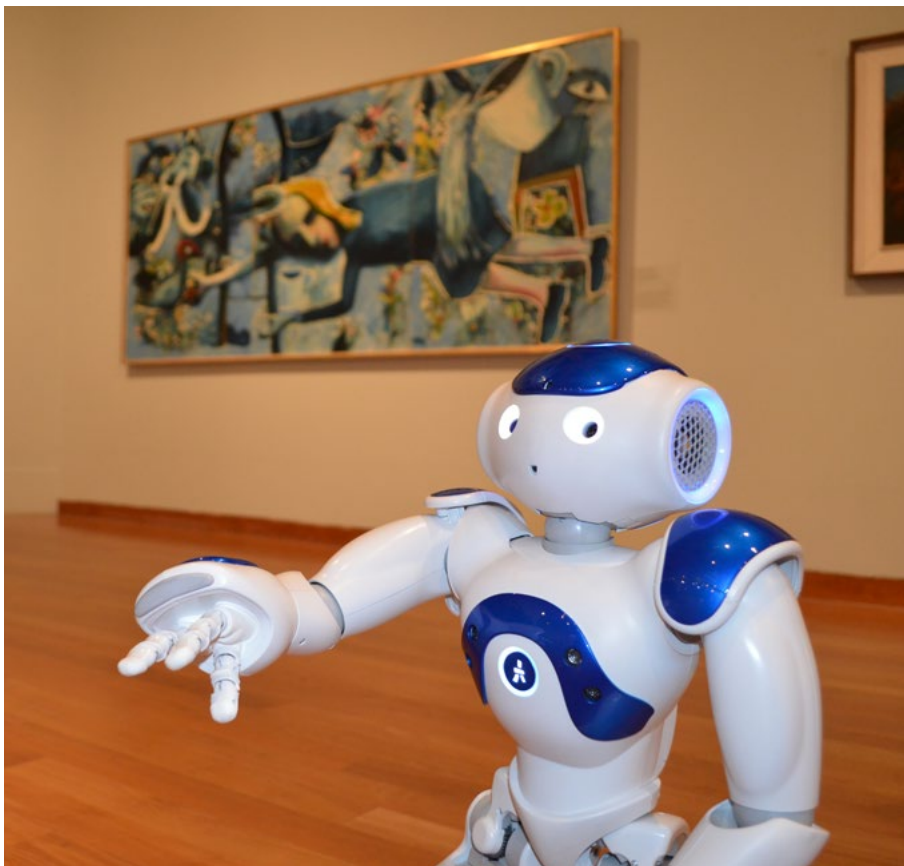
**VIDEOS**

[Aggie the AGWA \(Art Gallery of WA\) robot in action](#), 11 May 2016, ABC News online (1:28 min)

Take a look at other Nao robots in the video [Nao Robot](#), YouTube (2:52 min)

◀ Aggie the robot in the AGWA in front of **Charles Blackman Triptych Alice** 1957. Oil and enamel on Masonite, 124 x 276.9 x 6cm (framed). State Art Collection, Art Gallery of Western Australia. Purchased with assistance from the Friends of the Art Gallery, 1988. [Source: ©AGWA. With permission]



## 4.4 Robots into the future

*Smart robots are already here. They have beaten world champions in both chess and Go. Many intelligent robots and drones are in use in the military and some, like the General Atomics MQ-9 Reaper are armed. Machines have replaced workers doing manual labour and soon, as artificial intelligence becomes more advanced they will be doing cognitive labour. Serious scientists predict robots having human-like intelligence somewhere between 2029 and 2050.*

*This section looks at examples of intelligent robots that are able to learn, manufacture other robots and create original artwork.*

### Intelligent robots: machines learning

Everyone was shocked when IBM's Deep Blue supercomputer beat world chess champion Garry Kasparov in 1997. But Deep Blue was not the human-like intelligence that the world of Artificial Intelligence (AI) was looking for. Deep Blue, was purpose built with very fast processors to play chess by evaluating 200 million board positions per second.

Fast-forward to 2016, when Google's, DeepMind *AlphaGo* computer program beat the professional Go player Lee Sedol at a highly publicised tournament in South Korea. Sedol has attained the highest rank of nine-dan and is among the top three players in the world. It has been said that the methods underlying *AlphaGo*, and its recent victory, have startling implications for the future of machine intelligence.

The Chinese board game is considered to be a much more complex challenge for a computer than chess. Although the rules of Go are simpler than those of chess, there is more depth and complexity. This is because a player typically has a choice of 200 moves, compared with about 20 in chess and according to DeepMind's team there are more possible game combinations in Go than atoms in the universe.

The *AlphaGo* software combines neural network algorithms and machine-learning techniques and runs on powerful but fairly standard hardware.

Initially, it built up its expertise by studying older games and teasing out patterns of play. Then DeepMind trained the machine on 30 million expert moves. Finally, *AlphaGo* split itself into two, and played against itself, continuously improving its overall performance by learning from experience. Being able to play a million games per day compared with a human who might play a few hundred in a year, gave it a distinct advantage.

The game of Go has always been considered the ultimate test of artificial intelligence, therefore the win will spur on further work in this area. It will be helped significantly by the DeepMind team who have published a detailed description of the algorithms and parameter settings they used to generate *AlphaGo*.

To learn more about the match read the article Koch, Christof '[How the Computer Beat the Go Master](#)', 19 March 2016, Scientific American.

### The long road to getting robots to walk and run

While watching the newest model of Honda's ASIMO running, jumping, spinning and climbing stairs, it would be easy to underestimate the difficulty of getting robots to move successfully around in the world.



▲ **Deep Blue** (Source: Jim Gardner, Flickr, [CC BY 2.0](#))

### ■ ASIMO

► [Asimo at a Honda factory](#). This humanoid robot was created by Honda Motor Co. as a part of the research project **A**dvanced **S**tep in **I**nnovative **M**obility and was inducted into the Robot Hall of Fame in Pittsburgh in 2004 as the first humanoid droid able to walk dynamically [Source: Wikimedia Commons, Vanillase, [CC BY-SA 3.0](#)]

ASIMO has been in development for a period of 30 years (since 1986) when Honda first began its project to produce a humanoid robot.

One of the first hurdles was walking on two legs, beginning with a flat-footed shuffle that took 15 seconds for each step. A more natural gait followed, with the milestone in 1992 being the robot able to walk without support and climb stairs. More rapid progress was made in the new millennium—after the year 2000—because of advances in computers, hydraulics and microcircuitry.

Now 1.3 m tall, ASIMO detects obstacles, diverting to avoid them, as well as distinguishing people by voice and face. It can manipulate objects, like opening a bottle and pouring a drink into a glass.

With such a long and expensive development process, Honda hopes that ASIMO may one day become the ears, eyes, hands and legs of people who need help in their everyday lives.



#### VIDEOS

To see ASIMO performing everyday tasks in a number of different videos go to <http://asimo.honda.com/asimotv/>

#### ACTIVITIES

The ASIMO Honda website has an education section with activities for students 8 years of age and over. See <http://asimo.honda.com/education-materials/>

### ■ Spot and Cheetah

Spot and Cheetah are both four-legged robots that move around avoiding obstacles using on board LiDAR, which is the same technology that enables driverless cars to negotiate the roads.

[Spot](#) can walk around indoors and outdoors, up stairs and over rough terrain. Its back-facing rear legs, like those of goats, make it very stable. This allows the robot to react to external forces in a way that lets it remain upright even when kicked and pushed.

#### VIDEO

To see how Spot moves take a look at the video [Fido vs Spot — Animal vs Robot](#), YouTube (1:54 min)

[Cheetah](#) can run at 45 km/hr and jump objects up to 45 cm high. Its lasers map out the terrain in front so that it is able to accurately judge the height and distance of the obstacles it encounters. Cheetah's distinctive feature is that all of the computing is on board, meaning that it is completely autonomous.

### ■ Atlas

At 1.8 m tall and weighing 150 kg, [Atlas](#) is an imposing figure as it walks across rough terrain, avoiding obstacles and retaining its balance just like a human. With a laser range finder and stereo cameras linked to an onboard computer, it reacts to external forces and is able to get up unassisted if pushed over. Its combination of fine motor skills and strength enables it to find and open doors, climb ladders and move debris making it ideal for search and rescue tasks.

Advances in the control systems that enable human and animal-like movement across rough ground is a huge step towards robots that will be able to accompany people out into the world for search-and rescue operations, or move easily around the homes of elderly or sick people and to look after them.

### VIDEO

To learn more about these robots view the video: [5 Amazing Robots 2016 - The Shape of Things to Come - Atlas, Spot, Cheetah, Pepper, ASIMO](#), YouTube (12:21 min)

### RoboHow – How robots can learn from each other

A great way to make robots more useful would be if they could update themselves when they need to learn new tasks.

RoboHow is a European research project that commenced in 2012. The project's goal was to develop robots that could carry out 'complex everyday human-scale manipulation activities in both human working and living environments'.

Cooking is one of the typical daily household activities where robots could assist people who are injured or incapacitated in some way. Most recipes are quite detailed and cover a number of preparation steps. For example, cooking something like pancakes is very hard to reduce to a series of computer instructions. This is because it is relatively easy to program a robot to do a specific task, but it is much more difficult to get that robot to a stage where it can autonomously decide how best to undertake a task. The robot would need to know the best way to manipulate the utensil when flipping pancakes, not to mention deciding when the pancake is cooked just enough.

RoboHow will teach robots how to put information together, use it, and remember it for the future: that is to program themselves. A robot will extend its repertoire by acquiring new skills using web-enabled and experience-based learning, as well as by observing humans.

In the second part of the project, the robot will communicate what it has learned to an online database called OpenEase. This instruction website will create an open, easily accessible repository of growing knowledge for any robot to tap into and learn from.

So if a robot that was having problems with a manipulation task, say pouring a glass of water, for example, then the robot could itself access this archive, and learn how to go about the task. In this way it is almost like a 'Wikipedia for robots' that robots themselves could access to learn new skills.

The length of time it will take to construct this kind of repository for robots depends on how many people contribute. It could be started by focusing on narrow domains, for instance something like chemical experiments or industrial assembly. Then its coverage could be widened, with people contributing information from all different knowledge domains.

The team leader, Dr Michael Beetz, a professor for Computer Science at the University of Bremen Germany is confident that the project is feasible and that it will improve interoperability in robotics and lower the barriers for robot programming. (See [Robohow](#) website.)



▲ RoboHow robot flipping a pancake (Source: © Michael Memminger, [robohow.eu](#))

### Evolutionary robots

Taking robot autonomy even further is a project which focuses on mimicking the act of life itself—reproduction. Fumiya Lida from the Department of Engineering at the University of Cambridge in the UK is working on a project in which a mother robot creates more robots, which have improved mobility. He calls this evolutionary robotics.

In this research, the mother robot used materials from the environment to construct a group of child robots. The mother then assessed the ability of each child robot to move. Once she had selected those that move well, she improved upon their design and made a new generation of child robots that could move even better. Using trial and error in this way, the mother robot improved the design over many generations.

Initially, the mother robot built something with a very random design and the child robots just moved around a little without much success. But after building hundreds of robots—the largest experiment constructed 500 child robots—the mother robot came up with pretty good solutions and researchers observed up to 500 per cent improvement in locomotion.

This sequence of selection and development occurred without ongoing help from programmers. During the process, the mother robot developed some understanding about what was good and what was bad, so could be regarded as becoming creative. Of course, the robot's creativity was not as great as human designers, but this investigation showed that robots can be made to be creative and innovative rather than just repeating the same pre-programmed actions.

(See '[On the origin of \(robot\) species](#)', 12 August 2015, Research News, University of Cambridge and Lida, Fumiya. '[How we built a robot that can evolve — and why it wont take over the world](#)', 18 December 2015, *The Conversation*)

### VIDEOS

'[On origin of \(robot\) species](#)', YouTube (0:32 min)

To learn more about the evolutionary process of creativity in robots go to the Ted-Ed lesson '[Can Robots Be Creative](#)'.  
TedEd. Watch, Think, Dig Deeper, Discuss

### Creating creativity in machines

In general, computer scientists want their software to do exactly what it has been told to do. But Professor Simon Colton, who is Professor of Computational Creativity at the University of London, is investigating whether he can get software to either do something interesting or something creative.

Colton has developed a sophisticated software system called The Painting Fool, that has been programmed to mimic the creativity found in humans—with an understanding of things like mood and colour and the skills to paint and draw. But will it ever be considered an 'artist'?

The software has now completed around 200 portraits of very different types. This is not just programming; the computer autonomously chooses its style for each piece of artwork it creates.

When it paints, Professor Simon Colton says "I never have any sense of whether it's going to be in a good mood or a bad mood; what painting style it's going to choose, what abstract art it's going to put in the background, what image filter it's going to do, what painting style it's going to apply. And I also don't know how it's going to feel about the portrait produced at the end."

In terms of creativity and unpredictability, the project can be considered a success because, when someone sits down in front of it, Simon has no idea whether it is going to even paint that person's portrait, never mind what kind of portrait.

In terms of success as a recognised artist, the software's artworks have already been exhibited in both France and Britain. (See '[Making machines more like us](#)', 15 November 2015, Future Tense, ABC Radio National.)

### VIDEO

To see a video of robots replicating a drawing as it is being done view the video [Can robots draw?](#) ABC Splash, (0:46 min)

## Australian Research

### Western Sydney University

Researchers in the School of Computing, Engineering and Mathematics at Western Sydney University are investigating the ways in which robots can interact with environments and humans using computer vision. Our Robotics and Mechatronics Engineers are investigating new ways of using robotic arms known as manipulators to enhance advanced manufacturing processes. They are researching towards programming robots with demonstration based programming techniques. Working with robotic manipulators in particular, they attempt to program by demonstrating a task and then have robots copy human actions to repeat the task. Having robots copying human movements mean that they can be more easily programmed and enables the robotic technology to be used by people whether they have programming skills or not.

► **Baxter, an industrial manufacturing robot is programmed to outsmart opponents at the popular game of Connect Four. (Source: ©Western Sydney University)**

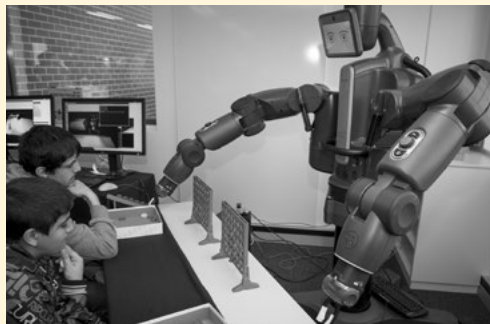

This takes extensive work in the vision and signal processing areas and our team aims to develop innovative concepts, methodologies and techniques in the fields of robotics, computer vision and signal processing and apply these developments to solving practical problems. One such problem also involves drones, where a PhD student is working with these vision and signal processing areas to program these drones to pursue suspects. Through human recognition, the aim is for the drone to keep track of these suspects on pursuit and assist police in their tracking of these suspects.



▲ **Researchers from the Engineering faculty work with the automated manufacturing robotic assembly at Western Sydney University (Source: ©Western Sydney University)**

◀ **Milo, a Hanson Robokind humanoid robot with an expressive 'frubber' face is used for experiments in nonverbal communication. (Source: ©Western Sydney University)**

For more information on the School of Computing, Engineering and Mathematics see [westernsydney.edu.au/scemresearch](http://westernsydney.edu.au/scemresearch)

Other researchers working with humanoid robots in the MARCS Institute for Brain, Behaviour and Development have developed technology for controlling these robots using motion-capture. The key innovation in their work is that their teleoperation system uses machine learning (artificial intelligence) to learn the kinematic mapping between the human and robot's differing bodies. This program focuses on the interaction between humans and machines, where machines include traditional computers, as well as robotic and virtual agents. We look at psychological and technological aspects of the interaction between humans and computerised systems, including visual analytics systems; investigate trust in robots and virtual characters and identify elements that make interactions with machines more efficient, useful and reliable. Apart from the focus on the interaction aspect in this program we are also interested in creating new technological facilities supporting the development of robotic and virtual agents that possess advanced intelligence and are capable of complex and multimodal interaction with humans and other machines, and intelligent visualisation systems for data science and analytics.

For more information on The MARCS Institute for Brain, Behaviour and Development see [westernsydney.edu.au/marcs](http://westernsydney.edu.au/marcs).

## CHAPTER 5: EXPLORING SOME OF THE SCIENCE

*Robotics truly represents the integration of STEM — Science, Technology, Engineering and Mathematics. In this chapter some of the science used in robotics will be explored.*

A robot typically has a movable 'body' which is made from combinations of different materials, usually plastic and metal, a motor, a power supply and a computer 'brain'. The power supply is usually a rechargeable battery or solar cells. The computer 'brain' is programmed and controls the robot by sending messages through the electric circuits in its 'body'. The robot may also be controlled remotely using WiFi.

The diagrams below show the Robonaut robotic hand developed by NASA and its structural components. It is easy to see how STEM contributes to the construction of this complicated device.

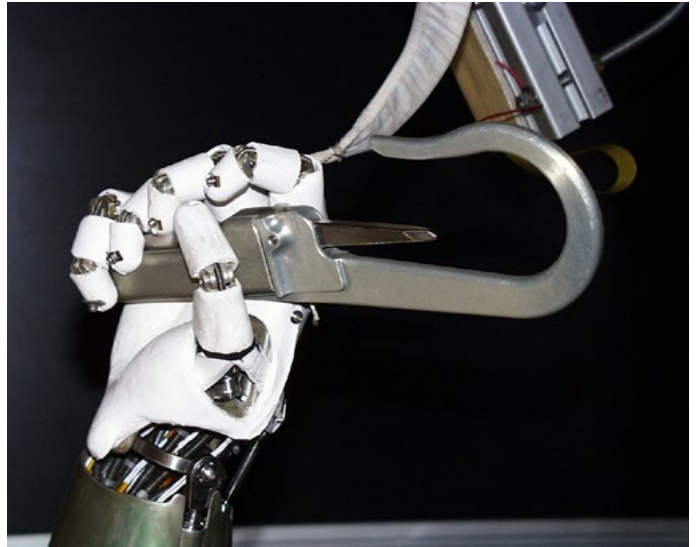

▲ [Hand of a Robonaut grasping a tether hook.](#) (Source: NASA)

► [Illustration of Robonaut's hand](#)  
(Source: NASA, Public Domain)

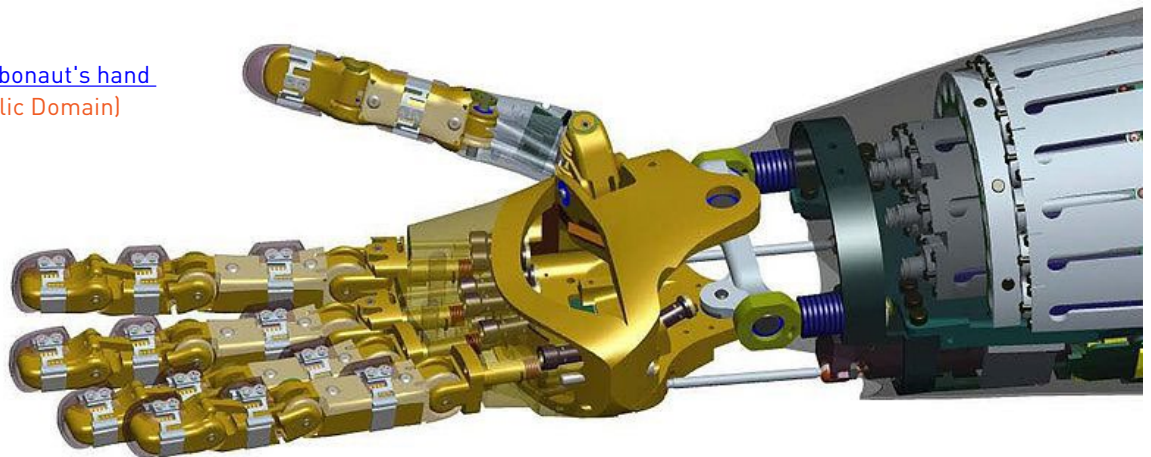

### 5.1 Communicating remotely

How can one object communicate with another when they are not connected? For example, how does a person control the flight of a drone flying in the air? The answer involves using waves as the means of transferring energy (and information) from one point in space to another.

But what are waves? Sound and light are two examples of waves that we all have some experience with, but they are quite different forms of wave. As humans, we communicate with others usually by our voice. We create sounds from the vibration of our vocal chords. The shape of our mouth and teeth then alter the vibrations to produce specific sounds with different frequencies.

Sound is an example of a mechanical wave, a wave that requires a medium to vibrate in order to transfer the energy from the source to the receiver. The sound energy is transferred via collision from one particle to another from the sound source to a receiver. In the example of human communication, the source of the sound energy is our vocal chords, the receivers of the sound energy are our ears and air is the medium through which the sound waves travel.

So we use sound waves to communicate between individuals, but how do we communicate remotely with electronic devices such as drones?

Remote communication uses an electromagnetic wave, which unlike sound does not require a medium to vibrate. These waves use a combination of electric and magnetic fields to transfer energy and coded instructions, and can do so through a vacuum or through air and many other materials. These electromagnetic waves are forms of electromagnetic radiation. Light is an example of this type of electromagnetic wave and was covered extensively in the 2015 National Science Week teacher resource book [Making Waves: The Science of Light](#).

### VIDEO

For a more detailed explanation of electric and magnetic fields view the video [Electromagnetic waves and the electromagnetic spectrum|Physics|Khan Academy](#) YouTube (11:01 min)

We know that light can travel through a vacuum. Think how light comes to us from the sun. The light wave travels through space all the way from the sun to the Earth. These waves are self-propagating and do not require particles to vibrate to travel from one place to another.

The light waves travel via a combination of an oscillating electric and a magnetic field in the same way as a radio wave or TV wave travels from a radio or TV station transmitter to the antenna connected to the radio or TV in your house or apartment. However, the antenna must be tuned to the precise frequency and wavelength of the source wave sent out from the radio or TV station transmitter to work.

We cannot see the radio or TV wave or the electric and magnetic fields, but we know they exist because we use other methods of detection than sight. These waves carry information that can be decoded and converted back into electric currents that can operate the device recreating the original light and sound waves produced at the radio or TV source.

Electromagnetic (EM) waves like radio waves, infra-red or microwaves are produced in special antennas called transmitters, that vibrate electrons creating electric and magnetic fields that radiate out from the transmitter. Antennas in the receiver of the device then pick up these EM waves. The antenna contains electrons that vibrate in response to the electromagnetic fields of the wave it receives. The original source material can then be reformed on the device using the instructions embedded within the EM wave.

In radio communication, information such as sound is converted by a transducer into an electrical signal via a device such as a microphone. The electrical signal is then modulated as a radio wave and sent out from a transmitter. A receiver intercepts the radio wave and extracts the information-bearing electronic signal, which is converted back using another transducer, such as a speaker, to replicate the original sound wave.

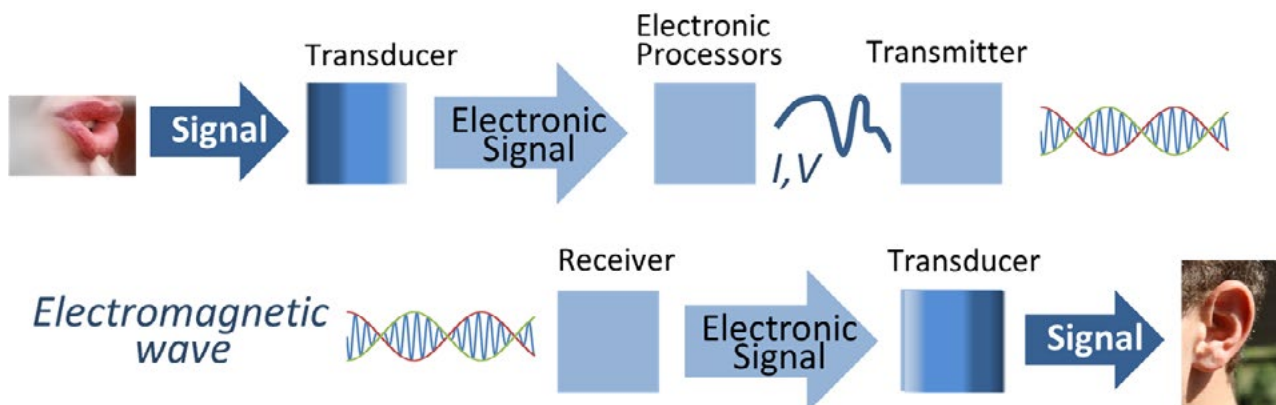

### ▲ [Steps in a signal communications system](#) (Source: Brews ohare, Wikimedia Commons, [CC BY-SA 3.0](#))

You may have heard of AM and FM as types of analog radio waves. These waves are radio waves that carry information such as sound. They can do so by systematically altering some property of the electromagnetic waves transmitted through space. The property of the wave that is often altered includes their amplitude (AM) or frequency (FM). This coded information is said to 'piggyback' on the radio wave. An audio signal (top) may be carried by an AM or FM radio wave.

► This diagram depicts how AM and FM can be used to transmit a radio wave [Source: UC Davis, ChemWiki, [CC BY-NC-SA US](#)]

Today we also use digital codes to transmit information on radio waves. The information carried by digital signals sends the information as a series of numbers, a digital code, using the numbers 1 and 0.

For more information on AM, FM and digital radio see '[Radio](#)', Explain that stuff.com

There are different types of electromagnetic waves all of which travel at the speed of light (300,000 km/s) through a vacuum or in air. Together these EM waves make up a spectrum known as the 'electromagnetic spectrum'. Visible light is one very small part of this spectrum. Fortunately, our eyes are capable of seeing these waves when they are reflected off objects or if something like the sun or a computer screen produces its own light.

We make use of various EM waves, particularly at one end of the spectrum, for communicating between devices or for sending information over incredible distances. Remote controls that operate things like televisions, air conditioners, garage doors, other entertainment systems and game consoles all work using electromagnetic waves. These EM waves have low frequency and longer wavelengths than the EM waves at the other end of the spectrum.

#### VIDEO

For more details on the electromagnetic spectrum and how the different types of EM waves are used view the video [The Electromagnetic Spectrum](#), YouTube (5:19 min).

Most modern devices use either low-end infrared waves (like the TV remote), microwaves (computer wireless networks and mobile phones) or radio waves (toy cars) to send command instructions between the controller (the remote) and the receiver (an antenna on the device being operated). Each of these waves has specific frequency bands within which they operate. Some of these frequency bands are reserved for particular purposes, such as radio and television stations. Other frequency bands have been set aside for specific industry, scientific or medical purposes. One of these specific applications we use every day—WiFi, which has special significance to Australia and the CSIRO.

► The electromagnetic spectrum from lowest energy (longest wavelength) to highest energy (shortest wavelength) [Source: ©Astronomy: Science Without Limits, [ASTA](#)]

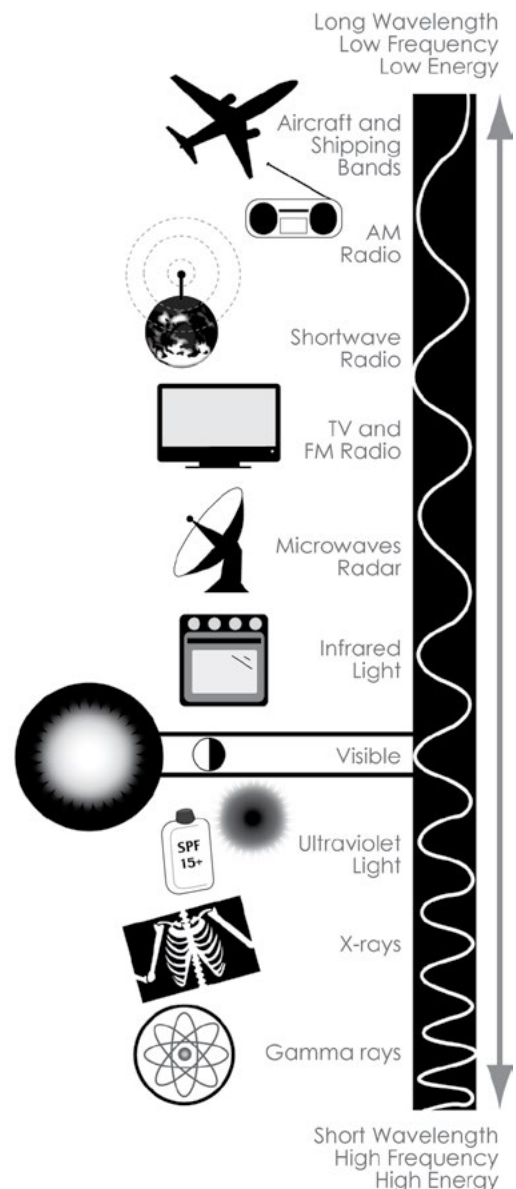
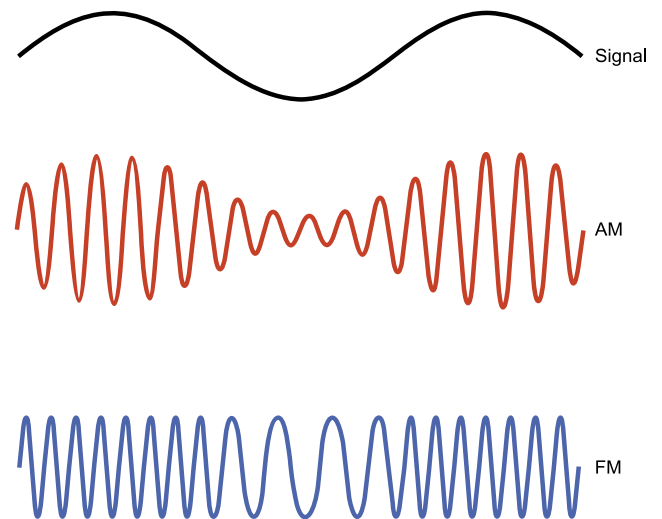



## WiFi

Almost all of us have made use of a WiFi network at some point in our lives. Every time we access a wireless network such as with a smart device, video gaming platforms or our computer networks at school, we are using WiFi technology.

### Did you know that WiFi is credited as an Australian invention?

A group of Australian radio astronomers led by Dr John O'Sullivan and including Dr Terrence Percival AM, Graham Daniels, Diethelm Ostry and John Deane working for the CSIRO, developed a key patent without which WiFi could not function. The patents taken out by the CSIRO in 1992 and 1996 were for a method that enabled WiFi to 'unsmear' the signal so that the wireless transmission can be used effectively to transmit data.

## VIDEOS

To see the true story of the invention of modern WiFi view the video '[WiFi Windfall](#)', 8 October 2009, *Catalyst*, ABC TV (12:03 min)

To see the impact of WiFi on robotics take a look at the video and images at [A robot future](#) (Chapters 1–6) ABC Splash website.

WiFi is a local area wireless computer networking technology that allows electronic devices to connect to a network, mainly using the 2.4 gigahertz Ultra High Frequency (UHF) and 5 gigahertz Super High Frequency (SHF) sections of the Industry, Scientific and Medical (ISM) radio bands. WiFi is often referred to as 802.11 networking, a designation that comes from the Institute of Electrical and Electronics Engineers (IEEE) standards that sets the standard for a range of technological protocols. The term WiFi is often confused as meaning *Wireless Fidelity*, an advertising slogan initially used after the brand name was first used.

It would be a very different world if WiFi did not exist. The invention of WiFi has made so many common daily activities much easier and convenient. Could you imagine every task that relies on WiFi technology, if wires were needed to replace the 'wireless signal' used to send the necessary information to make things operate? We appreciate being able to go almost anywhere and still being able to communicate using our smart devices and other mobile data services.

## 5.2 Flight

A drone is a vehicle that is usually an unmanned aircraft that can be remotely controlled. They may also be capable of flying autonomously through the use of embedded flight plans that are controlled by software carried by the drone that works by using GPS navigation and positioning systems.

A drone may be constructed in such a way to replicate a plane or a helicopter. Irrespective of its design, its function is to be able to fly, or in the case of helicopter type drones, to also be capable of hovering in a fixed position.

To fly or hover, any object must overcome the force of gravity to remain in the air for any length of time and have access to an energy source to supply the necessary kinetic energy required for movement. A force is defined as a push, pull or twist that can change the shape of an object, speed of an object, or its direction of travel and is an important concept in understanding how things fly.



▲ Crews inspect a research drone before its test flight at NASA Langley Research Center to make sure it is fit to fly. (Source: [NASA Langley/David C. Bowman](#))

There are four forces that act together when an object is flying or hovering. These forces are weight, lift, drag and thrust. These are essentially two pairs of opposing forces (lift v's weight and thrust v's drag) that obey Newton's Three Laws of Motion.

▼ Forces acting when an object is flying or hovering.  
(Source: [NASA](#))

### VIDEO

For an explanation of the forces acting in flight view the video [The Aerodynamics of Flight](#), YouTube (0:45)

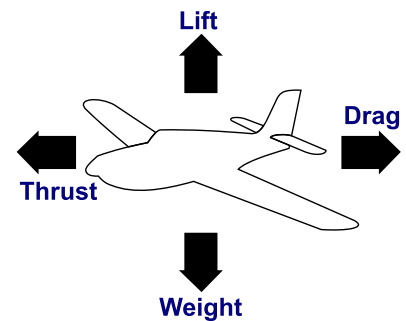

Weight is a force that acts downwards towards the center of the Earth due to the gravitational attraction of the mass of the object, such as a drone, to the Earth. Lift is a force that acts upwards to overcome the weight force of the drone and is created by differences between air pressure above and below a wing or a rotor in the case of a helicopter, due to its shape. Thrust is the force provided by an engine that propels a drone or plane in the direction of the motion. Drag is the force created by friction due to the resistance of the air and differences in air pressure.

These two sets of opposing forces act with different magnitudes at different stages of flight or to manoeuvre a plane or drone during flight. To take off, a drone requires greater thrust and lift to overcome weight and drag. To fly normally, weight is equal to lift and drag is equivalent to thrust. To land, lift must be less than the weight force and drag must be greater than thrust.

Changing direction in flight requires components of the lift and thrust to act in a different direction to components of the weight and drag forces.

In order for a helicopter type drone to hover, lift must be equal in magnitude to the weight force and thrust and air resistance must be both equal to zero newton to remain in the same position.

### INTERACTIVE

Use the interactive '[Future Flight Design Center](#)', NASA to explore more about flight.

## 5.3 Circuits

All electrical technologies including WiFi, telecommunications, droids, drones and robots, all require the use of electrical circuits to function. An electrical circuit is a pathway along which an electric current can flow, where an electric current is a flow of charge. In reality, an electric current is a flow of electrons called real current or electron current. By convention, however, it was defined as a flow of positive charge—the charge carried by a proton, which is known as conventional current.

Electric current is defined as 'the rate of flow of charge' where charge is measured in the unit of coulomb that is abbreviated using the symbol (C). Electric current is measured using the unit of ampere or amps that is abbreviated using the symbol (A). One ampere (1A) is therefore equivalent to one coulomb per second (1 Cs<sup>-1</sup>).

The circuits we use to make electrical equipment work can be very simple or quite complex. There are however, two basic forms of electric circuit—series and parallel.

A series circuit is one in which each electrical component used in the circuit is connected consecutively to the next in one complete pathway. The charges that flow through the circuit can only move using the one pathway.

▼ Diagram of a simple series circuit.

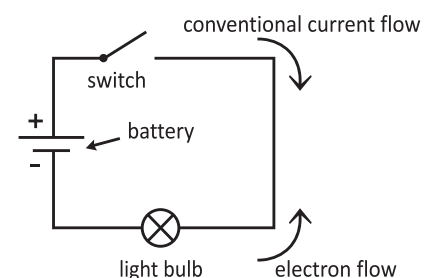

### VIDEO

To see an animated example of a circuit using a single light bulb watch the video [Explaining an electric circuit](#), YouTube 2:26 min)

A parallel circuit is one in which components are connected together enabling the current to flow using more than one pathway. The charges flowing through the circuit meet junctions where the current must split in two or more pathways depending on the number of 'branches' in the circuit. Series and parallel circuits in combination produce the more complex circuits. These are used in many electronic devices, computers and the circuit boards used in droids, drones and robots.

**VIDEO**

To learn more about circuits watch the video [Types of Circuits](#), YouTube (1:38 min)

▼ Diagram of a simple parallel circuit with two 'branches' that each contains a light bulb.

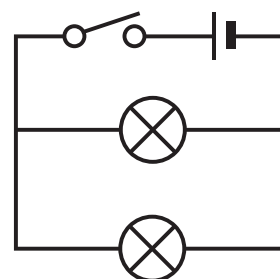

Every circuit requires a source of energy—charges which carry the energy to where the energy undergoes transformation and a complete pathway. If a circuit is incomplete the charges are unable to flow. A switch deliberately breaks this circuit and stops the current from flowing. A switch enables a circuit to be turned on or off.

The type of circuit will affect the characteristics of the circuit. For example, in a simple series circuit containing light bulbs, as you add more light bulbs and switch the circuit on, each light bulb will become dimmer than if only one light bulb was connected. Each light bulb requires electrical energy to transform into light energy (and heat). The energy comes from the cell or a battery of cells. If one cell is used with more than one bulb, each bulb is sharing the available energy from the cell. The more bulbs then the less energy each bulb is able to use as its equal share of the energy available.

In a parallel circuit, such as the one shown above, each light bulb would have the same brightness as if only one light bulb was connected in series. The two bulbs draw twice the amount of energy from the cell than used by a single light bulb as there are now two pathways along which the charges can flow. This means that the cell will go flat in about half the time compared to it being connected to just a single light bulb. When more light bulbs are connected in parallel, each will still have relatively the same brightness but more energy is being drawn from the cell each second. The advantage of parallel circuits is that they enable parts of the circuit to operate independently. The wiring in our houses uses parallel circuits so each light can be operated separately from all the others. It also means if a fault occurs in one section, the other sections will still operate.

Whichever type of circuit is used there still has to be a source of electrical energy, such as a cell, battery, mains supply or generator. Energy is measured using the unit of the joule (J). In an electrical circuit the energy delivered by the moving charges undergoes transformation into a different type of energy.

The amount of electrical energy delivered by each unit of charge is defined as the potential difference or voltage (V) and is measured using a special unit known as the volt that is also abbreviated using the symbol (V). One volt is therefore equivalent to one joule per coulomb ( $1 \text{ J C}^{-1}$ ). We use the unit volt quite often in our lives. For example, most cells that we use in portable electronic equipment are rated at 1.5 V, 3.0 V or 9.0 V. A car battery is considered to be 12.0 V. A cell rated at 1.5 V can deliver 1.5 joules per coulomb of charge. Similarly, the car battery rated at 12.0 V can deliver 12.0 joules per coulomb of charge. If we connect the cells in series the potential difference is the sum of voltage of each of the cells, so if four 1.5 V cells are connected in series the potential difference becomes 6.0 V.

Most portable electronic devices use cells and batteries to supply the energy when they are not connected to mains electricity. Most of these cells and batteries are DC or direct current sources. In a DC source, or a circuit connected to a DC source, the real current can only flow in one direction, from the negative terminal towards the positive terminal. When described using conventional current the direction of flow or charge is from the positive to the negative terminal.

When we use mains supply the real current is AC or alternating current. In an AC device real current also flows from the negative to the positive terminal, however, the terminals are oscillating from negative to positive a set number of times every second. In Australia, AC mains supply oscillates 50 times every second. This causes the charges to oscillate backwards and forwards within the circuit. The charges are still able to deliver the electrical energy to where it is needed as the charges are moving extremely quickly at around 6,000 km per second, not at the speed of light that many people think.

So, drones, droids and robots all require energy to function. If they are portable devices or devices that are capable of free movement they require an energy source that moves with them. To perform a particular function, the electrical energy needs to be delivered using an electrical circuit that could be a series, parallel or a more complex circuit.

**ACTIVITY**

For instructions on how to use play dough to make simple circuits go to [Play dough circuits 1: getting started](#), The Surfing Scientist, ABC Science.

**5.4 Materials used for construction**

There are a vast number of materials both natural and synthetic, which are used in our daily lives. Each material has specific properties and therefore can be used for specific purposes, e.g. the material used in electrical circuits must be able to be made into wires and also be a good conductor of electricity. Copper is the material that is used for this purpose since it has the required properties. Cost must also be considered when making a decision about which material is used for a specific purpose. However, this is only considered if there are two or more materials that have the appropriate properties for the specific use. Cost is usually linked to the availability and production of the material.

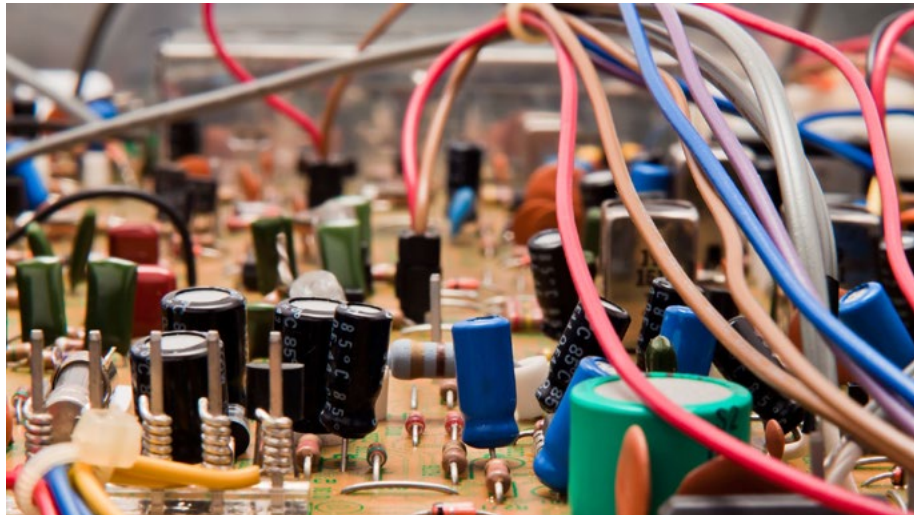

▲ Close up of a circuit board with electrical components and coloured wires (Source: ©Niels Kliim/123rf)

Drones, droids and robots have many different current uses and even more potential uses. Therefore, a variety of materials could be used in their construction, however, the choice of particular materials would depend on the use of the device. For example, unmanned aerial vehicles (UAVs) can be used to record footage at sporting events, to fly missions over enemy territory in wars and gather data in extreme conditions. The most common materials used are metals and composites.

**VIDEO**

To see how a drone was used to gather data about a volcano watch the video '[Drones sacrificed for spectacular volcano](#)' YouTube (3:30 min)



► Surveillance drone with onboard camera (Source: ©Llya Glovatskiy/123rf)

### ■ Composites

One of the earliest composite materials was glass fibre-reinforced polymers (GFRP), more commonly known as fibreglass. This is composed of glass fibres being coated in resin. Fibreglass was used because it is lightweight, corrosion resistant, temperature resistant and mechanically strong. It can be easily formed into complex shapes and is easily repaired and relatively cheap. There are different types of fibreglass due to the different ways that the glass fibre is woven and the different production methods.



To learn more about how fibreglass is produced look at:

- [Fibreglass manufacturing How fibreglass is made](#). YouTube (5:27 min)
- '[Fiberglass](#)', How products are made website

▲ Glass roving fibre for pultrusion process. (Source: Alexander Sorokpoud/123rf)

However, carbon fibre-reinforced polymers (CFRP) are now used for drones instead of GFRP because it is lighter and stronger. This is important because a lighter drone, needs less energy to keep it in the air. The improved strength of the CFRP allows the drone to be used in more adverse weather conditions without damaging it. A disadvantage of CFRP is that it is 5–25 times more expensive than GFRP, although it is still five times lighter than the same structure made from steel. However, the strength and decreased mass more than compensate for the increase in cost of production. CFRP is used wherever a high strength to weight ratio is required, e.g. aeroplanes, Formula One cars, crash helmets, laptop bodies, tent poles, golf clubs and drones.

Carbon fibre has the same atomic structure as graphite, however, the sheets interact differently. Therefore, carbon fibre consists of carbon atoms bonded in a continuous array of hexagons.

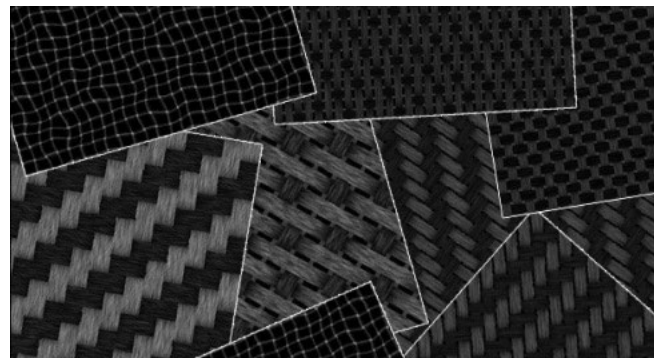
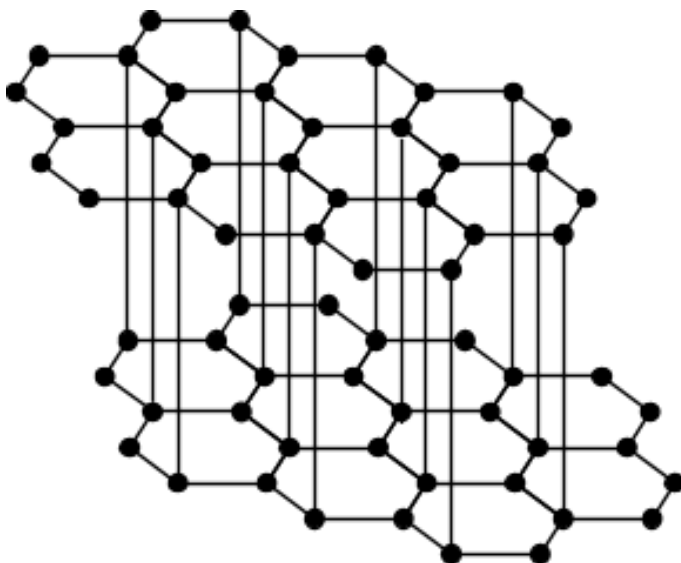

▲ Carbon fibre textures (Source: <http://carbonfibers.weebly.com/index.html>)

◀ Structure of graphite.

CFRP is a composite that has two parts—the reinforcement and the matrix. The reinforcement is composed of the carbon fibres while the matrix binds the reinforcements together. The most common matrix is an epoxy resin. Sometimes other substances can be added to the composite. Other fibres used include Kevlar while other binders could include polyester or nylon. Other additives such as silica, rubber and carbon nanotubes can also be used. Which materials are used is determined by the properties required.

Kevlar epoxy composites are used for propellers on drones. Many drones have four or more propellers, which can add considerable weight. The Kevlar epoxy composite is much lighter than CFRP, hence can considerably decrease the mass of the drone. It also produces a more stable flight since the propeller has less inertia and vibration.

Kevlar is a condensation polymer where the two starting compounds (monomers) react to form Kevlar and also produce hydrochloric acid as a by-product.

► [Formation of Kevlar from its monomers](#) (Source: Cacycle, Wikimedia Commons, [CC BY-SA 3.0](#))

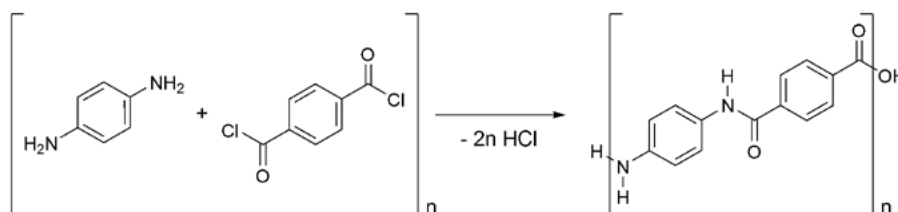

### ■ Metals

Sometimes composites do not have the required properties for use, so lightweight metals are used instead. Titanium is lightweight, strong and able to withstand high temperatures. This made it an ideal choice for some students from Melbourne University to use to build a drone that could be used by Victoria's Metropolitan and Country Fire Authorities to hover over a fire and send thermal images of the fire to the firefighters in real time (see Green, A. [Titanium propels 3D printed drone to aid in bushfires](#), 10 December 2015, CSIRO Blog). Another key property of titanium is that it can be used to produce complex shapes using a 3D printer, which could not be done using CFRP.

### ■ Latest developments

Scientists continue to develop materials that have potential applications in robotics, drones and droids. Below are some links to some of the latest developments:

- [Biodegradable drone melts away harmlessly after a mission](#), Gajitz.com
- Lovell, Daryl. 2016. [VIDEO: Morphing metal shapes future of soft robotics](#), Cornell University website (21 March 2016)
- Kirby, Carrie and Abate Tom. 2016. [Stanford researchers create super stretchy self-healing material that could lead to artificial muscle](#), Stanford News, Stanford University website (18 April 2016)
- [Robot folds itself up and walks away](#), Wyss Institute (7 August 2014)
- [UNSW Engineering's Automated Composites Laboratory](#), YouTube (1:59 min)
- [Time to make, bake and break](#), UNSW Engineering (19 April 2016)

## 5.5 Powering drones, droids and robots

All activity requires energy. Since drones, droids and robots all involve movement or processing of information, they also require energy. Importantly, they require energy sources that allow them to be able to operate in remote locations or allow them to move from place to place. The two most commonly used energy sources that are currently available are:

1. Batteries, i.e. electrochemical cells that convert chemical energy to electrical energy
2. Solar cells, i.e. photovoltaic cells that convert light energy to electrical energy.

### ■ Batteries — the basics

Batteries can be classified as either primary cells or secondary cells. Most batteries that you buy at a supermarket are primary cells. These batteries are used, then usually thrown into the garbage. However, they can also be recycled. They cannot be recharged.

Secondary cells are rechargeable batteries. Lead-acid batteries used in cars and lithium-ion batteries used in mobile phones, laptop computers and cameras are examples of rechargeable batteries.

Batteries only work when they are placed into an electric circuit. They involve the flow of electrons. Therefore, within the battery, there must be a reaction that releases electrons and another reaction that accepts electrons. An electrolyte, or conducting solution, must also be present. All batteries work this way, however, sometimes the chemicals used are quite complex.

Secondary cells are used for drones, droids and robots because they can be recharged many times before they need to be replaced. The most commonly used secondary cells are the lithium-ion cell and the lithium-polymer cell.

▼ Examples of secondary cells (a) Mobile phone batteries (b) Car battery (Source: a) ©Phittavas Phupakdee/123rf, b) Wikipedia, Public Domain)



▲ Primary cell batteries (Source: Razor512, Flickr [CC BY 2.0](#))



### Batteries — more technical information for upper secondary students

If you want to know more about the energy density of batteries and lithium ion batteries read on!

When considering energy sources for drones, droids and robots, it is important to consider their mass since the greater the mass, the greater the energy required to move that mass. Therefore, energy sources need to be made from lightweight materials. The devices also need to have a high energy density and a high specific energy.

$$\text{Energy density} = \frac{\text{Energy released by battery}}{\text{Volume (size) of battery}}$$

Energy density commonly has units of watt hours per litre (Wh/L). Hence, a smaller battery that releases the same energy as a large battery will have a higher energy density. This means that a higher energy density battery will take up less space than a lower energy density battery.

$$\text{Specific energy} = \frac{\text{Energy released by battery}}{\text{Mass of battery}}$$

Specific energy commonly has units of watt hours per kilogram (Wh/kg). Hence, a battery that has a lower mass but still releases the same energy as a battery with a higher mass will have a higher specific energy. This means that a battery with a higher specific energy will contribute less to the mass of the drone, droid or robot.

The figure above shows the energy density (horizontal axis) and the specific energy (vertical axis) for the five most commonly available secondary cells. The lithium-ion battery has a specific energy of 60–130 Wh/kg compared to the lead-acid cell which has a specific energy of 10–50 Wh/kg. Hence, the lithium-ion battery is much lighter than the lead-acid battery. The lithium-ion battery has an energy density of 200–300 Wh/L compared to the lead-acid cell which has an energy density of 50–100 Wh/L. Hence, the lithium-ion battery is much smaller than the lead-acid battery.

#### The lithium-ion battery

Watch this video to see how lithium-ion batteries are produced [Lithium batteries how they make them](#), YouTube (7:21 min)

The lithium-ion battery has the same components as other batteries—an anode, a cathode and an electrolyte. The anode consists of sheets of graphite with lithium atoms inserted between them. The cathode is composed of a lithium metal oxide such as lithium cobalt oxide (LiCoO<sub>2</sub>). The electrolyte is usually a combination of various lithium salts in an organic solvent.

Lithium-ion batteries that have different lithium metal oxide cathodes have different uses. For more information comparing the different types of lithium-ion batteries, go to the Battery University website [BU-205: Types of lithium-ion](#) and [BU-206: Lithium-polymer: Substance or Hype?](#)

► [Graph of mass and volume energy densities of several secondary cells \(by direction: down=heavier,up=lighter,right=powerful,left=weaker\)](#) [Source: Barrie Lawson, Wikipedia [CC BY SA 3.0](#)]

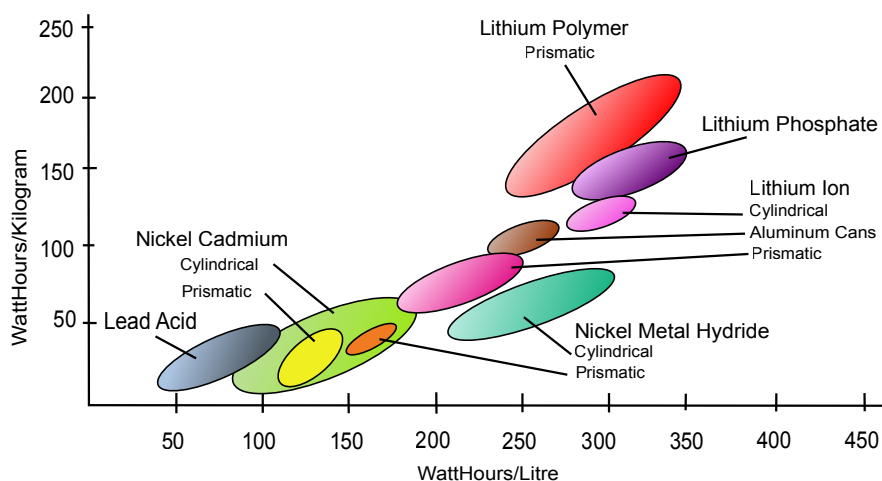



### ■ Solar cells

The use of solar cells in powering both fixed wing UAV and drones is a strong area of research. The expansive wings of a fixed wing UAV can easily carry a number of solar cells. As solar cells become thinner and more lightweight this capacity is increasing.

#### WHITE PAPER

Alta Devices (2015) [Whitepaper: Selecting solar technology for fixed wing UAVs](#), Alta Devices website.

This white paper discusses the key characteristics, tradeoffs and relevant metrics of the various solar photovoltaic technologies available today in the context of fixed wing unmanned aerial vehicles (UAVs).

In 2015, Facebook announced that it will start testing a solar-powered drone that 'will be able to fly without landing for three months at a time'. It will provide Internet access to remote areas by using a laser beam-to-beam data to a base station on the ground. However, the drone will have a wingspan the size of a Boeing 737! (See '[Facebook launches Aquila solar-powered drone for internet access](#)', 31 July 2015, The Guardian).

Google also announced in January 2016 it will be testing of solar-powered drones to deliver 5G Internet. The company is using an existing drone called Solara 50 made by Titan Aerospace for the tests. It carries 3,000 solar cells that produce 7kW of electricity. (See '[Project Skybender: Google's secretive 5G internet drone tests revealed](#)', 30 January 2016, The Guardian)

#### VIDEO

[Titan Aerospace Solara 50](#), YouTube (4:52 min)

#### The basics on solar cells — how do they work?

The Earth absorbs vast quantities of energy from the sun. The Earth's landmasses, oceans and atmosphere absorb more energy in about one hour than the Earth's population would use in one year! If only this energy could be harnessed. Solar cells are one technology that is currently being utilised to harness this energy—to convert the sun's energy into electrical energy. Solar cells are sometimes called photovoltaic devices—photo meaning light and voltaic meaning voltage. Hence, converting light energy to electrical energy.

Solar cells contain materials that absorb energy from the sun. This energy releases an electron from the material, which moves through an external circuit and back to the material. The most common material used in solar cells is silicon. Silicon is a semi-conductor. It does not conduct electricity as well as a conductor like copper, which is used for electrical wiring in our homes. However, it is not an insulator either. Insulators do not conduct electricity at all. Silicon is somewhere in the middle.

To increase the conductivity of silicon, some impurities are introduced into the silicon lattice. Silicon atoms are removed and either phosphorus atoms or boron atoms are added. About one in every million silicon atoms is replaced in this way. The silicon lattice that has phosphorus atoms substituted for silicon atoms is called n-doped. The silicon lattice that has boron atoms substituted for silicon atoms is called p-doped.

#### VIDEO

To see how n-doped silicon is produced watch the video: [Silicon irradiation at ANSTO](#), YouTube (1:06)



A solar cell is made by joining a p-doped layer of silicon to an n-doped layer of silicon, these are then connected to an external circuit. The sunlight hits the n-type layer. An electron is ejected and moves through the external circuit to the p-type layer.

▲ **Solar PV modules mounted on a flat roof**  
(Source: AleSpa, Wikipedia, [CC BY-SA 3.0](#))

▼ **Cross section of a solar cell** (Source: [Mrsolar.com](#))

#### VIDEO

To see the basics of how solar cells work, view the video [Energy 101 Solar PV](#), YouTube (2:01 min)

#### ANIMATION

To learn more about the chemistry of atoms and the physics of semiconductors, n-doping, p-doping and how the solar cell works view the animation [Photovoltaic cells](#), Sumanas Inc website.

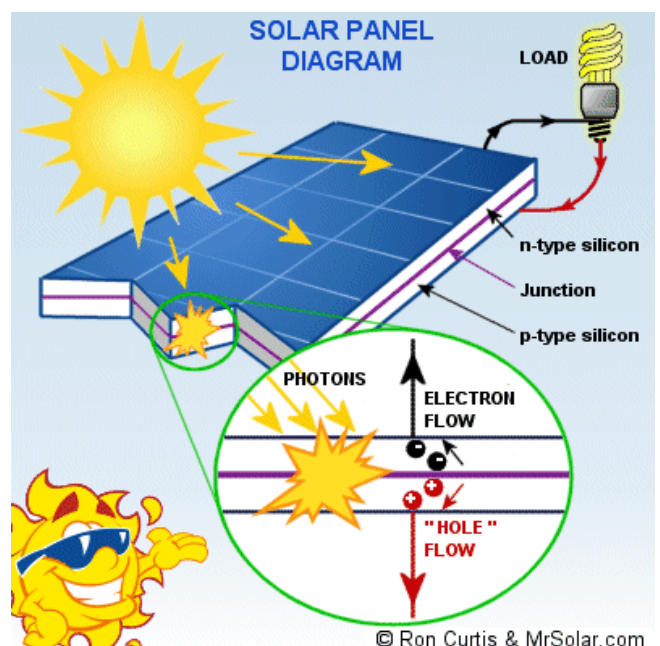

► Inside one kind of silicon-based solar cell (Source: [STELR](#))

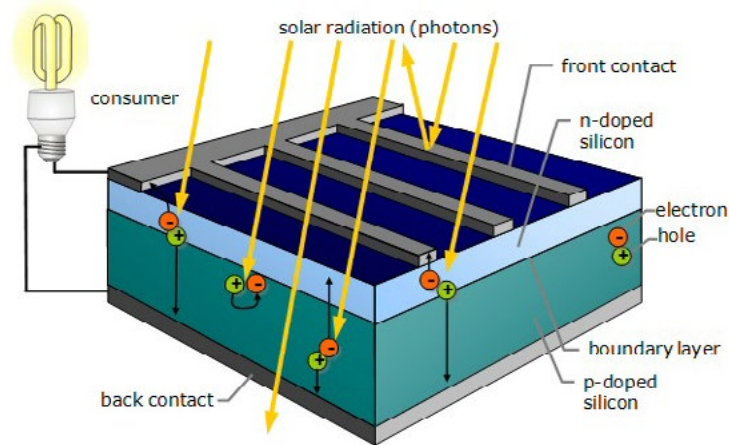

### ACTIVITIES

Make your own solar powered robot.

[Solar-powered robot](#), Instructable website.

[Build a solar-powered bristlebot](#), Science Buddies. Middle school.

Some devices use a combination of solar cells with either lithium-ion batteries. The solar cells can be used to recharge the batteries so that the device can operate both during the day and during the night.

### Fuel cells

Fuel cells are also being investigated as to their suitability for robotics. Fuel cells are similar to batteries. However, where batteries store energy, fuel cells can continue to operate as long as there is fuel and oxygen present. Fuel cells convert chemical energy to electrical energy. The most common fuel is hydrogen, which reacts with oxygen in the cell to produce water. Hence, one of the advantages of using this type of cell is that environmental pollutants are not produced. However, there are still some significant issues that need to be addressed if they are to be a viable alternative to current technologies in robotics, namely:

- Storage of hydrogen fuel
- Long life reliability
- Low power (Power = Energy / Time). Although fuel cells can operate for extended periods of time, the energy available per unit time is lower than for other current technologies.

Use the following links to learn more about fuel cells:

- [What is a fuel cell and how does it work?](#) Fuel Cell Institute of Australia Pty Ltd
- [Fuel Cell Basics](#), National Museum of American History, Smithsonian
- [Types of fuel cells](#), US Department of Energy

### VIDEO

To hear about another potential power source for UAVs—lasers—view the video:

[Alternative UAV power sources becoming a reality](#), YouTube, (1:59)

## CHAPTER 6: MATHS MAKES IT HAPPEN

*The importance of mathematics is often not emphasised when learning about drones, droids and robots. The emphasis is usually on the programming and construction of the device. However, the navigation and positioning in space of devices including drones, self-driving cars and robots has an important mathematical basis.*

Robots use sensors to move around and these turn their measurement of the outside world into numbers. Trigonometry and [inverse kinematics](#) are used to calculate the angles and lengths required for a robotic arm to successfully grasp and release objects. A robot uses statistics to 'learn'—to enable it to recognise patterns in data. (See McOwan, Peter. nd. [The maths within...robots](#), Maths Careers.)

The relationship between drones and mathematics is provided as an example of the importance of mathematics and links to the Australian Curriculum – Mathematics have been included.

A drone needs to be able to hover, fly and navigate through space. To hover is to stay in position and to navigate is about moving position. Position and change in position are where mathematics comes to play.

There are three ways of controlling the navigation of a drone:

- using a pilot,
- using GPS,
- using sensors on the drone to 'see' in a 3D world.

A pilot can control a drone from watching the drone or responding to images sent from cameras on the drone. Line of sight control of the drone generally uses a control stick on a remote controller. Can your students use direction language that matches movements they would make with an electronic game controller? (*Australian Curriculum: Mathematics (ACM), Measurement and Geometry (MG), Location and transformation Years F to 5*)

▼ [Hovering drone, Forgemind, Flickr, CC BY 2.0](#)

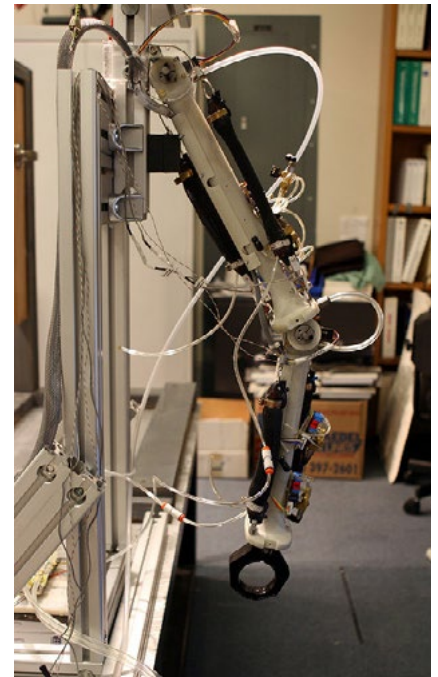

▲ [Robotic arm leveraging a combination of electric motors \(for precision\)](#). (Source: Erik Charlton, Flickr, [CC BY 2.0](#))

Public uses of drones (not commercial or military) have line of sight as a restriction. What is a reasonable distance to command a drone by line of sight? What are the factors that affect what is a reasonable distance? (*ACM Problem solving and Reasoning*)

To use GPS (Global Positioning System) the drone needs a GPS receiver to read signals transmitted from satellites. It calculates how far away a satellite is by using the time it takes the signal to reach the receiver. The distance from the satellite to the receiver is the radius of a sphere with the satellite at the centre of the sphere. Four satellites would give four different spheres that have a point of intersection in common. This gives the drone its position. The mathematics of determining this position is an extension of the geometry of circles. (*ACMMG Geometric reasoning, Year 10A*)

GPS has a number of weaknesses. GPS uses signals that are quite weak and can be interfered with accidentally or deliberately. Also using GPS a drone knows where it is and where it wants to be but does not know what the obstacles are between those two positions.

► Illustration of a drone flying over a cityscape [Source: ©Roberto Rizzo/123rf]

How high should a drone fly in your suburb to avoid all obstacles? How high should it fly over a farming district? How high should it fly over a town? How high should it fly over your capital city? (*ACM Problem solving and Reasoning*)

The idea of a drone seeing and navigating in a 3D world without a pilot is becoming a reality. Cameras and other sensors on the drone can use mathematics to develop a three dimensional map of the drone's local environment. Other software then commands the drone on its flight path to avoid obstacles.



The YouTube video [Real-Time Visual-Inertial Mapping, Re-localization and Planning Onboard MAVs in Unknown Environments](#) (1:33 min) shows a 3D map being generated from the sensors for the drone as it flies a particular path.

### ACTIVITY

Use blocks to make a model of your school or a local area. Ask your students to give a list of instructions to get from one point to another. Get other students to follow/test those instructions, perhaps using another block or figure. (*ACMMG Location and Transformation Years F to 5, Key Phrases: Landmarks, direction language, grid references, and routes*)

### VIDEO

To watch a year 6–7 student describe the use of maths in a pivot turn see [Robotics Club and maths](#), ABC Splash (2:01 min)

### VIDEO FOR EXPERTS (SENIOR SECONDARY)

[12 O'Quad High: Trigonometry in Flight](#), Teaching Channel (14:28 min)

▼ Drones [Source: Phil Parker, Flickr, [CC BY 2.0](#)]



## CHAPTER 7: ROBOTIC COMPETITIONS FOR SCHOOLS

There are many competitions available to students in the Science, Technology, Mathematics and Engineering (STEM) areas. The types of competition are quite varied. Some competitions are for individuals, while others are for teams. The age and divisions also vary. The competitions may involve multiple choice questions, open-ended problem solving exercises, design and construction projects, and/or experimental research. Entries may require submission of paper responses, uploading of photos, videos and documents to websites and/or physically attending a competition venue with equipment to compete. Information on many of these competitions can be found in [STEM Program Index 2016](#) curated by the Chief Scientist's Office.

The competitions listed below are those at a state, national or international level that specifically target, or have sections that target, the development and construction of 'drones, droids or robots'.

### Name: **FIRST® LEGO® League**

**Age level:** 9–16 years.

**Description:** Robot competition catering for upper-primary and lower-secondary school students. Teams of up to ten students build, program and compete with a robot, while also learning about a modern problem in science and engineering and developing solutions for it. The competition is based around a theme. Past themes include: natural disasters, senior citizens, food health and safety, climate change, medical science, and nanotechnology.

#### Resource requirements:

- A dedicated adult coach
- A LEGO Mindstorms EV3, NXT or RCX robot kit
- A place to meet to work on building robots, practicing games and working on the project.
- Registration fees: AUD\$400 for one team with one kit

**Competition organisation:** Regional in each state, state finals, national finals, Asia Pacific finals, World festival (USA).

**Curriculum links:** Mathematics, Science, Design Technologies, Digital Technologies and ICT.

**URL:** <https://firstaustralia.org/programs/first-lego-league/>

**Twitter:** [@FirstAustralia](#)

**Facebook:** [FIRST AUSTRALIA](#)

**Contact/Organiser:** Luan Heimlich, Director of FIRST Australia [luan.heimlich@mq.edu.au](mailto:luan.heimlich@mq.edu.au) (Macquarie University)

### Name: **FIRST® Robotics Competition**

**Age level:** 14–18 years.

**Description:** Robot competition catering for middle to upper secondary school students. Teams design, build, program and drive robots which compete to win a game. The game changes every year and no robot part from previous years is allowed to be reused so new robots have to be built every year. The competition game is designed to be like team sports and robots are not to be intentionally harmed. The game is always played on an 8 x 16 field and is played by 'alliances' of three teams each.

#### Resource requirements:

- A dedicated adult mentor
- Sponsors
- Equipment and materials for constructing the robot (Kit of parts available)
- A place to meet to work on building robots, practicing games and working on the project.
- Registration fees: up to USD\$6500 per team

**Competition organisation:** Regional in each state, state finals, national finals, Asia Pacific finals

**Curriculum links:** Mathematics, Science, Design Technologies, Digital Technologies and ICT.

**URL:** <https://firstaustralia.org/programs/first-robotics-competition/>

**Twitter:** @FirstAustralia

**Facebook:** [FIRST AUSTRALIA](#)

**Contact/Organiser:** Luan Heimlich, Director of FIRST Australia [luan.heimlich@mq.edu.au](mailto:luan.heimlich@mq.edu.au) (Macquarie University)

**Name:** *Oliphant Science Awards South Australian Science Teachers Association (SASTA)*

**Age level:** Reception to year 12

**Description:** The Oliphant Science Awards is a competition held annually for South Australian school students to develop their interest in science through a science-based competition with a range of categories: Computer Programming and Robotics, Crystal Investigation, Games, Models and Inventions, Multimedia, Photography, Posters, Science Writing and Scientific Inquiry.

**Resource requirements:** There are no specific requirements but participants must follow guidelines outlined on the website and pay a registration fee (ranges from \$8–\$16).

**Competition organisation:** This is a state-based competition. Some entries may be eligible to enter the National BHP Billiton Science and Engineering Awards competition.

**Curriculum links:** Mathematics, Science, Design Technologies, Digital Technologies and ICT.

**URL:** <http://www.oliphantscienceawards.com.au/>

**Twitter:** @SAScience

**Facebook:** [SA Science Teachers Association](#)

**Organisers:** [SA Science Teachers Association](#)

**Name:** *RoboCupJunior Australia*

**Age level:** Open to students studying at a primary school or secondary school (or the equivalent e.g. home schooled).

**Description:** Students work in a team of two or more to develop solutions to the RoboCup Junior Challenges in Dance, Rescue, and Soccer using LEGO MINDSTORMS EV3 Kits and Software. The focus in the junior league is on education. RoboCup is an international effort whose purpose is to foster Artificial Intelligence (AI) and robotics research by providing a standard problem where a wide range of technologies can be integrated and examined. The students must exclusively perform construction and programming of the Robots.

**Resource requirements:**

- \$80 per team (national competition)
- Advice: The competition is open to any platform. Some common examples:
- Include Hardware: LEGO Mindstorms (EV3, NXT, RCX), Arduino, Matrix, VEX, ...
- Programming Languages: NXTG, EV3, Robolab, Robot C....
- LEGO MINDSTORMS EV3 Kits and Software <http://www.teaching.com.au/catalogue?catalogue=MTA&category=MTA-LEGO-MINDSTORMS-EV3>
- RoboCupJunior Packs (Dance, Rescue, Soccer) <http://www.teaching.com.au/catalogue?catalogue=MTA&category=MTA-ROBOCUP-ROBOTICS-COMPETITIONS>
- Teacher Resource Books <http://www.teaching.com.au/catalogue?catalogue=MTA&category=MTA-MINDSTORMS-TEACHER-BOOKS>

**Competition organisation:** Regional in each state, state finals, national finals and an international competition.

**Curriculum links:** Mathematics, Science, Design Technologies, Digital Technologies and ICT.

**URL:** <http://www.robocupjunior.org.au/>

**Facebook:** [RoboCup Junior Australia](#)

**Organisers:** RoboCup Junior Australia (non-profit organisation with sponsors and university affiliations)

**Multimedia overview:** [https://prezi.com/z2yug1oktjna/robotics-and-the-australian-technologies-curriculum/?utm\\_campaign=share&utm\\_medium=copy](https://prezi.com/z2yug1oktjna/robotics-and-the-australian-technologies-curriculum/?utm_campaign=share&utm_medium=copy)

**Video:** RoboCup International is coming to Australia in 2019! <https://www.facebook.com/robocupjunioraustralia/videos>

**YouTube:** <https://www.youtube.com/user/RobocupJuniorAust>

### Name: *Robogals Science Challenge*

**Age level:** Years 1–9 | Ages 5–15 yrs [Junior (5–8yrs), Intermediate (9–12yrs), Senior (13–15yrs)]

**Description:** The Robogals Science Challenge is an Australia-wide science competition for girls, which allows participants to learn more about science and engineering through science projects and experiments with a friend, parent, or mentor. Entries to the competition are submitted online in the form of videos, photos and writing in three age categories (Junior, Intermediate, and Senior) or in a separate school category. The competition spans four months, with the best groups or individuals being rewarded for their efforts towards the end of the year. The competition is open from the 1st of May to the 5th of August, 2016.

**Resource requirements:** Internet. Other materials required depend on project, but can usually be found in local shops or craft stores. No specified software is required.

**Competition organisation:** The Robogals competition requires an online registration. Entries to the competition are submitted online in the form of videos, photos and writing in three age categories. The competition will span four months, with the best 12 participants awarded for their efforts at the end of the year.

**Curriculum links:** Mathematics, Science, Design Technologies, Digital Technologies and ICT

**URL:** [www.robogals.org](http://www.robogals.org) | (registration) <http://eepurl.com/bYjBg9>

**Twitter:** [@Robogals](#) | [@RobogalsAP](#)

**Facebook:** [Robogals](#) | [APRobogals](#) | [RobogalsScienceChallenge](#)

**Organisers:** Ruwan Devasurendra (Project Director) | Suhashi Wickramasinghe (Project Manager) [scichal@robogals.org](mailto:scichal@robogals.org)

### Name: *Young ICT Explorers*

**Age level:** The divisions are years 3–4, 5–6, 7–8, 9–10, 11–12. Students can compete individually or in project teams of up to four students.

**Description:** Young ICT Explorers is an open Digital Technology Challenge for school age students from year 3 to year 12 across Australia. It's free; there is no entry cost for students and schools. Students create a digital technologies project of their choice (mobile apps, wearables, robotics, website etc.). They can either showcase their passion or identify and solve a problem within their school or broader community.

**Resource requirements:** The software is not specified and the website provides suggestions and access to free industry standards software for teachers. Templates and advice about acceptable file types for upload are provided on the website.

**Competition organisation:** Registrations were open from February 1st 2016. Teachers needed to register their school's interest before the 12 June 2016 via the website. Students need to be signed up and projects submitted by the 24th of June in QLD, NSW, Vic and Tas or until the 1st July in the ACT, SA and WA. Entries are judged online and some are selected to present at state finals and then at a national final.

**Curriculum links:** Mathematics, Science, Design Technologies, Digital Technologies and ICT.

**URL:** <http://www.youngictexplorers.net.au/>

**Twitter:** [@YoungICTExplore](#)

**Facebook:** [Young ICT Explorers](#)

**Organisers:** Young ICT Explorers Organising Team, SAP Australia Pty Ltd, [info@youngictexplorers.com.au](mailto:info@youngictexplorers.com.au)



## CHAPTER 8: SNAPSHOTS OF WHAT'S HAPPENING IN SCHOOLS

There is a lot happening in schools in the area of STEM (Science, Technology, Mathematics and Engineering). Information on over 250 STEM programs, resources and opportunities can be found in [STEM Programme Index 2016](#)—a new guide compiled by the Office of the Chief Scientist. It includes in-class, after school, holiday and online activities and resources, catering to a wide and growing range of students.

This chapter provide educators with a snapshot of some of the learning opportunities for students in the areas of drones, droids and robots. The schools featured represent a range from those just beginning their programs to those that having been running them for many years. There are primary and secondary schools from a variety of states and territories and educational systems. The profiled schools were identified by colleagues, professional associations and state and national education systems as those that might provide a representative snapshot of what is happening across Australia. They are by no means the only schools conducting programs in these areas.

The schools, in alphabetical order, which have graciously provided information and images on their programs, are:

- Canberra Grammar School – ACT
- Good Shepherd Lutheran College – NT
- Gordon East Public School – NSW
- Hammond Park Catholic Primary School – WA
- Mentone Girls Grammar – VIC
- Playford International College – SA
- Quantum – VIC
- West End State School – QLD

### *Canberra Grammar School (ACT)*

**Teacher:** Matthew Purcell (Head of Digital Innovation)

**Name of program:** Drone School.

#### **What is the aim of the program?**

Our aim with this project was to increase engagement and enthusiasm in STEM by showing that programming has far more applications than writing code on a computer. As such, it is incredibly important for students to have an appreciation and understanding of how code and computing powers modern society. To this end, we introduced drone programming into our IT courses and co-curricular Code Cadets program. This provided students with an opportunity to take the concepts of coding they have learned and apply this towards the novel and highly hands-on activity of programming drones for semi-autonomous and fully autonomous flight.

As a secondary aim, we also wished to improve cross-curricular collaboration between departments at the school. Initially it was envisaged this would occur between the IT department and the Science Department (aspects such as aeronautics and the physics of flight) however, the most cross-curricular collaboration happened between the IT department and the Art and Design department.

Finally, we also aimed to further educate the students in the need to be precise, calculated, and analytical in their thinking processes. This was an aim which was not apparent from the outset but became obviously important as the project progressed.

#### **Curriculum being addressed:**

Digital technology, with cross-curricular links to science and design.

#### **Why did you start it?**

We offer a range of code-level subjects from years 7 to 12, starting with our year 7 and 8 Code Cadets co-curricular programme through to year 9 and 10 IST and year 11 and 12 SDD. Our students are very engaged with the technical programming content, but are only provided with limited exposure to the applicability and consequences of programming and software development – writing software which runs on a desktop computer or mobile device.

The advent of consumer drones that use open-source operating systems (Linux), along with responding to common programming languages (C, Objective-C, Swift, JavaScript), has provided an ideal way to engage students in physical, real-world, and real-time system programming.

Including drone programming in our curricula and co-curricula IT programmes would engage our students in practical software development with physical and real-time consequences (i.e. wrong code = drone crashing). This form of feedback also impacts the students more than simply a program on a computer crashing, providing a more memorable feedback loop where the students learn from mistakes.

There are currently very few school-targeted materials and units of work for this topic, so this project would also contribute back to broadening the available materials for all teachers to use.

#### **How did you start it?**

The project was rolled-out in stages. We first started by running the project only for our year 8 Code Cadet students during Term 4 2014—which was a reasonably small group of approximately 10 students. This was a very important pilot program as it highlighted technical issues which needed to be addressed before the program could be reliably and safely rolled-out to larger classes of students. Interestingly, most of these issues only became evident when using a large number of drones simultaneously—such as wireless network interference issues and airspace considerations.

Some of these issues could not be overcome, such as the wireless networking interference, and we are still working on better solutions to those problems. However, having known these issues we were able to formulate plans which minimised their impact allowing a roll-out to larger groups of students such as IT classes.

There have been several public displays of our own drone operations including a feature event in the school Launch festival, involving night-time flying of the drones synchronized to music in the main quad at the school. As an experiment, we also attached remotely controlled LED light strips to the drones, which provided amazing visuals against the night sky.

#### **How long has it been running?**

One year.

#### ▼ Drone night at Canberra Grammar School



**What year levels are involved?**

Years 8–10.

**How is the program run?**

- At Canberra Grammar School we offer the following:
- Year 7 Code Cadets: Co-curricular (2 groups, Tuesday and Wednesday afternoons). Python and Arduino programming.
- Year 8 Code Cadets: Co-curricular (1 group, Friday afternoons). Arduino programming.
- Year 9 IST: Curriculum (2 classes, 3 ppw). HTML, CSS, and JavaScript programming
- Year 10 IST: Curriculum (2 classes, 3 ppw). Swift (iOS) programming.
- Year 11 and 12 SDD: Curriculum (2 classes, 4 ppw). Visual Basic programming.
- Senior Code Cadets (1 group, Friday afternoons). Extension and enrichment for year 9–10 IT students.

The project primarily integrated into our offerings for years 7 to 10, given the scope in those courses for custom units of work (compared with the relatively inflexible requirements of the year 11 and 12 SDD course for the HSC).

To avoid overlap in content within the year groups, particular focus units were developed and planned for specific year groups so that, for example, students in year 10 do not repeat the same work they complete in year 9.

All classes are held at different times (there are no clashes) so one class set of drones can be used with all the classes.

**What resources are needed and how did you access these resources?*****Drone hardware***

When implementing a course about programming drones the first aspect to consider is the drones you will be using. For this project, we selected the Parrot AR.Drone 2.0 quadcopter platform. Matthew Purcell who is the Head of Digital Innovation already has experience in programming drones, through his own experimentation with an AR.Drone and programming the device in various different languages.

In particular, we chose the Power Edition version which includes two high-capacity 1500 mAh batteries providing approximately 18 minutes of flight time each (although actual flight time varies substantially depending on aspects such as prevailing wind, manoeuvres being completed, etc.). You should be able to bank on getting at least 10 minutes of flight out of one fully charged battery.

The AR.Drone 2.0 platform was chosen for several reasons:

- The drones are reasonably affordable at approximately \$500 for the Power Edition. Yes, this is quite a bit of money but when you consider that other drones are over \$1000 this is a reasonable price, when you also consider the other features of this platform.
- There is an SDK (software development kit) for the platform, allowing for developers to write code which interacts (e.g. controls) the drone—the exact purpose of this project.
- As the drones rely on WiFi for the control link, rather than RF, this makes it easy to link the drone to a computer for control and programming.
- The drones are running an embedded version of Linux, allowing for some serious hacking of the platform (for more advanced students).
- There is a large community of developers who write third-party libraries for the platform, along with doing other interesting hacks—meaning there is plenty of support and resources available.
- The drones are reasonably safe as they are made out of styrofoam and plastic, rather than carbon fibre (found on more expensive drones, making them much more hazardous if they run into something or someone!). That said, we still would not recommend running into anyone with these things!
- The drones are modular, meaning if something breaks (e.g. due to a crash) then the parts can be purchased to repair the drone, which is a good experience for the students, in that if they break the drone they need to fix the drone.
- There is an indoor hull and outdoor hull. The indoor hull has rotor guards, and is useful for when students are first learning to fly the drone as less damage would be done if it runs into something or someone, compared with a drone without the guards.
- Finally, they are very easy to fly (with self-stabilisation features) and suitable for students without any previous flight experience.

We purchased all our AR.Drone hardware through Modlife Store. They have provided us with excellent customer service, prompt delivery, and is our continued supplier of spare parts.

**Computing hardware**

Computing hardware and devices are the other part of the equation and used to control the drone.

- iOS or Android device. When students are first beginning to use the drones, it is useful to provide them with basic flight experience using the AR.Drone Free Flight software available on the iOS App Store and Android Google Play Store. This provides them with an understanding of how the drone flies at a very basic level.
- Laptop computers. To program the drones, laptop computers are needed. We found the best platform to be MacBook laptops, as they can easily install the required tools. Windows machines can also install the tools, but it does require a bit more effort.

**Software requirements**

All software needed for the project is available for free, making it accessible for students to load onto their own devices and computers.

**Mobile software**

In order to initially fly the drones on mobile devices (e.g. iPhone, iPod Touch, iPad, Android) software is needed from the relevant app store for the device. The most suitable software is Free Flight, published by Parrot (the manufacturer of the AR.Drone) and provides an easy-to-use app for students to play around and get familiar with the drones.

For iOS devices, Free Flight is available for free at: <https://itunes.apple.com/au/app/freeflight/id373065271?mt=8>

For Android devices, Free Flight is available for free at: <https://play.google.com/store/apps/details?id=com.parrot.freeflight3&hl=en>

**Computer software**

There are many different software packages which can be used to control the drones from a computer. This project uses the node-ar-drone project from GitHub to program the drones using Node.js (a variant of the JavaScript programming language): <https://github.com/felixge/node-ar-drone>

**Legal requirements**

It is important that you understand the law and the legal restrictions on flying drones. In Australia, the laws about the flight of drones (also known as RPAS [Remotely Piloted Aircraft System], UAVs [Unmanned Aerial Vehicles], or UAS [Unmanned Aerial Systems]) is governed by Civil Aviation Safety Regulations (CASR) Part 101. There is a handy summary guide provided by CASA which is worthwhile to distribute to all students: [https://www.casa.gov.au/sites/g/files/net351/f/assets/main/lib100071/flying\\_with\\_control\\_model.pdf](https://www.casa.gov.au/sites/g/files/net351/f/assets/main/lib100071/flying_with_control_model.pdf)

However, it is still important to read the full regulations to understand your responsibilities and restrictions particularly relating to what's classified as not hobby or sport operations.

**RPAS training course**

We recommended that teachers involved in a drone project attend an RPAS training course. This is usually a one-week course which trains you in proper operation and flight of UAVs. At the end of the course, assuming that you pass the theory and practical assessment components, you are issued with a UAV Controllers Certificate from CASA. Amongst other things, this permits you to fly UAVs for commercial gain under an operator who holds a UAV Operators Certificate (this is somewhat akin to holding a pilot's licence, which then allows you to fly under an airline). Even if you do not intend to fly commercially for an operator, the course still provides you with a lot of information about safe and legal operation of UAVs.

**Are you involved with other schools/groups/organisations?**

We have also been fortunate to engage with several Canberra-based commercial UAV operators, such as Overall Photography and FPV Australia. In the case of Overall Photography, they kindly visited the school at the end of 2014 and demonstrated their large UAVs (including a DJI S1000) to the entire year 8 cohort during a year group meeting. This was a big driver in encouraging uptake in the year 9 IT course for 2015, getting the students engaged and excited about this technology and the ability to work with the technology as part of their coursework.

**How do you think the program is going so far?**

The most notable project success has been the increased engagement with computer programming, providing students who

are not interested with the traditional notion of programming (i.e. writing software which purely runs on a computer) with an avenue to become involved in this space through alternative means. Another success has been the increased profile this program provided IT and Technology at the school – given the ‘cool factor’ of drones, when they are flying other students are often very curious and interested about how they can get involved—driving increased uptake in our curricular and co-curricular IT offerings at the school. That said, while the ‘cool factor’ does have the immediate appeal to encourage uptake of the subject, there needs to be longevity and legitimacy in the content to drive participation in the longer-term. Fortunately, given the curriculum and activities which we have developed surrounding the drone program, this is provided so it’s not just a one-off interesting thing to do, but has the potential for longer-term student engagement.

We are not aware of other schools who have a drone program on the scale that we are offering, so this was certainly an experiment in what works, and what doesn’t work. We did find that quite a few things did not work as we expected—primarily related to technical aspects, along with some classroom management style aspects:

- Interference between the drones. As the Parrot AR.Drone quadcopters each broadcast an ad-hoc Wi-Fi network for the control link, if there are any more than around 4 or 5 drones in a small area then the spectrum becomes so congested that the links regularly drop-out, or you cannot see some of the drones at all. This is even worse if it’s an area with other Wi-Fi networks (such as a school campus network).
- Airspace considerations. If working with a class (of standard size, around 20 students, which would operate about 10 drones, assuming 1 drone per 2 students) then a very large area is needed to avoid the interference issue described above, along with just ensuring that the drones don’t crash into each other. Ovals are most suitable, preferably with trees or a high fence surrounding in case of a fly-away (uncontrolled drone which flies away by itself).
- Student management. Ensuring that students fly the drones responsibly and always with control. It is very difficult to monitor a full class flying the drones, and it is surprisingly hard to always see where the drones are flying, particularly if some are at different altitudes and flying against a clear or overcast sky with not much contrast between the drone and the sky.

Additionally, integration into the year 10 IT course was difficult and could not be achieved. We initially intended to write an SDK for the AR.Drone in Swift (as there is no existing SDK for Swift) but did not have the time to complete this aspect. Instead, we limited the drones to our Code Cadets co-curricular program and our year 9 IT course (using the open source node-ar-drone library).

These are certainly not classified as ‘failures’, but rather challenges to be overcome—some of which were unexpected (such as the interference issue) whereas some were expected, but not necessarily to the degree in which they manifested themselves (such as student management considerations).

#### **What advice do you have for teachers who might like to run a similar program?**

This is a project which has already attracted quite a bit of attention, with several schools emailing us directly for more information and resources. Our goal has been to provide ready-made resources so that other schools can implement a similar program, and also so they can learn from our experiences (and mistakes!) given this is a very unique and new project.

We have established a website on GitHub at <http://canberragrammar.github.io/DroneSchool> which contains all the artefacts from our project, including resources, activities, and lesson plans. This also hosts the various bits of sample source code for programming drones. All the material is licensed under a Creative Commons Attribution-NonCommercial-ShareAlike 4.0 International License, so the material can be used and adapted by other people and organisations so long as it’s not used commercially and shared under the same licence.

As this is area in which other schools wish to engage, we also want to foster a community of educators who are involved in drone-related operations and programming. This is one of the key reasons we are using GitHub – so that other educators can comment, provide suggestions, and contribute back to the project (we welcome pull requests on our GitHub repository). We would like to make this project open source such that everyone can learn from everyone else’s experience, successes, and failures.

#### **Useful contacts:**

Matthew Purcell (Head of Digital Innovation at Canberra Grammar School)

[Matthew.Purcell@cgs.act.edu.au](mailto:Matthew.Purcell@cgs.act.edu.au)

### **Good Shepherd Lutheran College (NT)**

**Teacher:** Raul Luis Monteiro Moizao.

**Name of program:** Engineering and Robotics.

#### **What is the aim of the program?**

The aim of the program is to introduce students to world of Engineering through practical Computer Science projects, focused predominantly in Robotics.

**Curriculum being addressed:** [Technologies/Digital Technologies](#)

#### **Why did you start it?**

A need was identified at our school regarding abstraction, transferable knowledge and problem solving abilities in the technological area. The traditional ICT subjects effectively introduce students to the digital world, but they lack effectiveness regarding the development of the fundamental computational thinking skills that our student will need in their future lives. They are mainly focused on the use of technology tools from the user point of view that, although necessary, present a deficit in the afore mentioned areas.

Simultaneously, students need to have the ability to deconstruct real life problems, work with available data, cooperate, explore different ways of showing relationships and patterns, summarise facts, deduce conclusions and communicate without the fear of being wrong.

Engineering is an excellent starting point to achieve these goals. It employs practical science to produce technology, using mathematics as a language. It addresses real life problems, promotes communication and cooperation in order to produce technology that, usually, needs to be evaluated and redesign. It also treats error and failures as learning opportunities, sources of knowledge, and develops computational thinking and abstraction.

Robotics are excellent tools for introducing students to the different Engineering fields. Robots can be assembled in different ways to address different functions and purposes, building up on previous familiar knowledge of construction blocks. Robots execute tasks, introducing students to computational thinking through algorithms and problem solving, developing on abstraction and transferable knowledge.

#### **How did you start it?**

Our Engineering and Robotics programs started in 2015 in year 8 (40 hours), year 9 (60 hours) and year 10 (120 hours), simultaneously. It was decided that the lower year levels would start with an introduction to engineering, in order to develop their abilities in the area in the subsequent school years. Year 9 and year 10 that had traditional ICT subjects in the previous school years would skip the introduction in order to maximise the available time for Robotics. Both year 9 and year 10 started with same program in 2015.

In 2016, the year 10 program was changed to cater for the students who had completed it in year 9.

#### **How long has it been running?**

Since 2015.

#### **What year levels are involved?**

Years 8, 9 and 10.

#### **How is the program run?**

To introduce students in year 8 to Engineering we start with communication. To communicate we need to have something to communicate, information. We need to have a media to transmit such information in the form of a message that can be understood by others, a common code, a language. Starting with this familiar topic, students cooperatively discuss different types of communication evolving to data representation and computer codes. Students research different types of computer networks and, in groups, design and produce local area networks, wired and wireless. This acquired knowledge is then transferred and used in Robotics: Bluetooth to remotely access robots and wireless for drone control.

To run this program, we use four old school switches that were not in use, and a Wireless Access Point.

The base of all year 9 and year 10 pedagogy is a combination of Problem Based Learning and Collaborative Learning. Students cooperatively discuss the definition of algorithms and are guided to define it as a "set of rules for solving a problem

in a finite number of steps". Simple problems are presented to the students and, in groups, they are asked to design and present the algorithm that solves it in whatever form they choose, from writing to sketching. The algorithms are cooperatively discussed in a whole class approach.

As the problems increase in difficulty, the students recognise the need for a common language and pseudocode is introduced. Resources like the [Hour of Code](#) are useful at this time to cement this knowledge. Students are then introduced to robots as a way to apply those found solutions in a real world environment. New familiar problems are then introduced, like instruct the robot to move forward 1 metre.

Students are guided to cooperatively transfer knowledge from human tasks to robots: humans have two legs, robots two motor wheels; humans move in steps, robots in rotations; both have to be informed how to represent distances in the metric system.

Results are discussed as all class approach in order to detect common errors and possible optimizations. When students feel comfortable in problem solving they then produce, following the [design cycle](#), a more ambitious project of their choice, negotiated with the teacher.

To run this program, we use 5 LEGO EV3 Robots, which the students share.

The year 10 program was changed in 2016 to cater for the students that completed the year 9 program in 2015. It assumes that students have basic knowledge in algorithms and introduces students to broad areas of Engineering with focus on Mechanics, Planning and Computer Science.

In year 10, students are presented with the missions and objectives of the FIRST LEGO League Completion from the previous year. Following the program pedagogy, students cooperatively design and discuss strategies for achieving the most points in the least time, as well as the mechanic structures needed for to achieve those goals.

Students are guided to discuss different heuristics and are formally introduced to them. Simultaneously students develop more complex algorithms that require variables, constants and an interaction between different sensors and actuators simultaneously. When students feel comfortable with the basic concepts in all three areas they select one and join in groups to produce a more ambitious project of their choice, negotiated with the teacher.

In the middle of the program the robot programming language is replaced with formal programming languages, usually Python and JavaScript. Student then start the Final Project that might be an advance robot or drone programming.

To run this program, we use ten LEGO EV3 Robots and one Parrot Drone 2.0.

In all programs, and since students learn in different rates and have different interests and projects, Blended Learning is extensively used, with all courses having a Moodle page containing resources, wikis, specific forums and tasks.

### Are you involved with other schools/groups/organisations?

Our Engineering and Robotics Program captured the interest of the NT Department of Education, and the developed work has been presented in two distinct Personal Development sessions. Good Shepherd Lutheran College NT is currently assisting in the development of a NT foundation to year 10 Coding and Robotics Program.

### How do you think the program is going so far?

Overall the program proved to be a success. At the end of each unit, students largely achieved the ACARA outcomes defined for their year level. Students finishing year 10 were able to design and construct robots projected on mechanical engineering principles and to write complex computer programs in standard programming

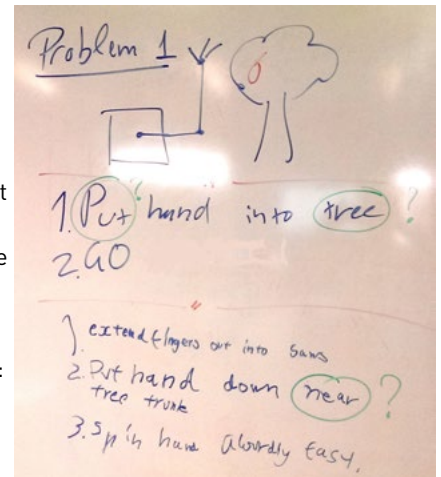

- ▲ Simple problems and discussion
- ▼ Structured problems

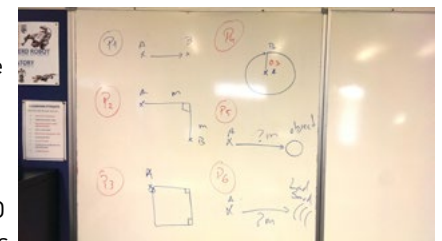

- ▲ Testing: from angles and metres to rotations

### ▼ Moodle page example

**Algorithm**  
A step-by-step problem solving procedure, especially an established, routine computational procedure for solving a problem in a finite number of steps.  
(from The American Heritage® Dictionary of the English Language, 4th Edition)

**To Practice**

- Hour of Code  
Write your own algorithm to move a character in a maze (from CODE Source)
- Prizes  
Write your own algorithm to move a character over a set of trees (from CODE Source)

languages. They also proved to be able to perform simple project managing and to be versatile in problem solving, facing error as normal step in the production process. The success is even more evident when addressing students with special educational needs. These students usually perform above average standard with little or no changes in the program.

GSLC at FIRST LEGO League competition, Brisbane 2015 ►



### Do you have any advice for teachers who might like to run a similar program?

Although significant knowledge is required, teachers do not have to have it to start a program. It is feasible to start with basic guided activities, like the [Hour of Code](#), and let students surprise you. They often do in Program Based Learning. Use your experience to guide them; remember that there is plenty of available resources online; and do not be afraid of showing that you do not know all. Use that as a common learning experience.

### Useful contacts:

Raul Moizao

[raul.moizao@ntschoools.net](mailto:raul.moizao@ntschoools.net)

## Gordon East Public School (NSW)

**Teacher:** Mrs Jenny Garlick.

### Name of program:

Release from year 2 to year 6 face-to-face LEGO Robotics Program.

### What is the aim of the program?

Our school robotics program has many aims and intended educational outcomes.

These include:

- Development of team skills including mentoring

The children develop team skills so they can work collaboratively to produce high quality work. They build on each other's ideas, regularly provide and receive constructive feedback, listen to each other, are mutually supportive, cooperate, share, take turns, contribute equally to the work load, treat each other with respect and kindness, discuss and share ideas, value each other and feel included. There's no 'I', it's 'we' and the collective whole is greater than the sum of the two individuals.

Mentoring skills are explicitly taught to students. As mentors they learn to be patient, understanding, and kind, encouraging, respectful, courteous, supportive, helpful and calm. They explain, demonstrate, guide, show and suggest what to do. Mentors do not take over. As mentors they troubleshoot when things go wrong and provide constructive feedback that is kind, specific and helpful. The mentor asks questions such as... "What about this?", "Have you considered...?", "Why don't you try...?", "What do you suggest?", "How could we improve this?". The mentor listens to the students they are helping and provides quality answers to their questions.

- Gifted and talented extension

The program provides great opportunity for open-ended problem solving which engages and extends the high achieving children.

- Providing a reason for some children to come to school

Some children find life really difficult, struggle with writing and are disengaged with school. Robotics can give them a reason to enjoy coming to school because they are good at the hands on building and designing or programming. The LEGO robotics program allows them to find a 'fit'.





- Promotion of boys' education

Robotics provides a platform where boys can become engaged and achieve. They really enjoy the hands on nature of the learning.

- Promotion of controlled risk taking and resilience

In the robotics classroom it is all about 'giving it a go'. Failure is not seen as a bad thing but an opportunity to ask 'why'. If everything works the first time, they haven't really pushed themselves, have they? Fail fast, ask why, and move on. And a failure is not really a failure; it just means that it didn't work. It's a process of elimination. Excellent resilience building comes from this.

- Using the classroom as a collaborative 'think tank'

In robotics any one can copy any one else, unless it's a test. This is because the classroom is a collaborative think-tank where children build on ideas from other students. If a team is stuck they 'go shopping' and walk around the room for inspiration and new ideas. The only rule is, if you use someone else's ideas, you must credit them. Copying is seen as the highest form of flattery as nobody wants to copy something that is not good.

- Coding

The children learn how to program their robots by coding. This is a logical, involves the correct sequencing of instructions, creation of flow charts and understanding the programming software. When the programs do not work as intended (or not at all) the students trouble shoot. This involves high order skills of analysis and provides great extension for the children. Proficiency in one coding program makes learning other programs easier. At GEPS the children program robots using different programs: WeDo, NXT Programming and Scratch.

- Designing and making

The robots are designed and made so they achieve the desired outcome while being stable and durable. There is the constant design, make, appraise cycle as the students' test their design and continue to make modifications until they are happy with the final product.

- Computer skills

Opening, closing, saving, key board short cuts, dragging icons, downloading, uploading and organising of files is part of using the computer to program robots. These universal skills can be transferred across to many other programs.

- Over lapping with maths, English, science, design and technology, engineering and visual arts.

Robotics provides a powerful platform to teach many subjects. All the robotics units of work at GEPS are integrated units addressing multiple Key Learning areas.

#### **Curriculum being addressed:**

Robotics addresses the digital technologies perfectly. As mentioned above it also a valuable tool to teach any of the KLAs especially maths, science and English.

#### **Why and how did you start it?**

The CSIRO carried out a Robotics incursion at the school I was teaching at back in 2004. It was love at first sight and I knew that was what I wanted to teach. I approached the P and C for funding and 18 months later they approved the purchase



of 2 class sets of RCX robots. The more I taught using the robots the more I believed in their incredible capacity to enrich the education of the children I taught.

**How long has it been running?** At GEPS the robotics program has been running for 5 years.

**What year levels are involved?** Years 2–6.

**How is the program run?**

At Gordon East Public school the Robotics program is taught to all students from year 2 – year 6 as part of the release from face-to-face teaching program. Years 2 and 3 receive 1 hour per week and the older children's sessions are 1 1/4 hours per week.

**What resources are needed and how did you access these resources?**

We are fortunate at our school to have many resources. The robotics program has access to a class set of computers so that children can work in teams of two.

Year 2 children share 15 kits of Early Simple Machines and Simple Machines.

Year 3, children have one set of WeDo per pair. The P and C recently purchased a class set of the new WeDo 2.

In year 4, each pair has a kit of WeDo with the resource set added in between two students.

Years 5 and 6 have one NXT Kit between two students

**Are you involved with other schools/groups/organisations?**

By maintaining a [blog](#) of what is happening in the LEGO Robotics classroom I am able to share work and communicate on-line with students, teachers and citizens around the world.

I have shared my experiences with other schools by presenting at conferences including the 'Engineering Conference' and the 'Killara High Schools Partnership conference' which was attended by neighbouring primary and secondary schools.

I have a relationship with Macquarie University Mac ICT and have team taught with Dr Sarah Boyd, Mrs Annika Lyttle and value the input from my colleague John Burfoot.

Student teams, which I have coached, have entered the First Entering into Competitions with great success. In 2014 the Gordon East Public School First LEGO League Team 'Feasting Fast Foodies' which qualified to attend the Australian National Competition at Macquarie University Dec 2014. In 2015–2016 the GEPS First LEGO League Team '[Trashmendous](#)' are competing in the International Razorback FLL Championships in Arkansas, USA.

**How do you think the program is going so far?**

I believe the program is going extremely well. It is well loved by the students and the staff value it as an excellent use of RFF time.

The school has a Gifted and Talented extension team [competing internationally in the FLL competition](#). I have been awarded the LEGO [Education Teacher Award for 2016](#) for primary school robotics teaching because of a program I have developed and implemented in the robotics classroom over the last 18 months.

**Do you have any advice for teachers who might like to run a similar program?**

If you are a primary school teacher start with the WeDo LEGO system. It is very manageable and the units of work that LEGO have produced to go with it are exceptional and absolutely adored by the children.

**Useful contacts:**

[Macquarie ICT Innovations Centre at Macquarie University](#) runs many excellent courses for staff and students to learn about robotics.



### **Hammond Park Catholic Primary School (WA)**

**Teachers:** Jacinta Petersen, Vicki Sheehy and Sinead Donnellan.

**Name of program:** HPCPS National Science Week Celebration.

**What is the aim of the program?**

1. To develop the student's conceptual understanding of robots, drones and droids through activities in Science, Technology and the Arts.
2. To engage children and their dads/father figures in hands-on robotic activities.

**Curriculum being addressed:**

Science, Technologies, The Arts.

**Why did you start it?**

Hammond Park Catholic Primary School is only four years old, with 207 students from Pre-Kindergarten to year 4. In 2015, the specialist area of Visual Art was introduced, and in 2016 for the first time, science has been introduced as a specialist area. A classroom teacher with high levels of technology skill also joined the school in 2016. Also beginning in 2016 with the introduction of a new P&F Executive, was a sub-committee of dads leading a group called the 'Secret Dad's Business'. This group began as a way to encourage dads to be involved in their children's education and provide social opportunities for them, connecting with the research-based Fathering Project.

We decided on two ways to recognise National Science Week in 2016. The first involves the Secret Dad's Business, which will be a joint dads and children robot building on Saturday 13 August. This will be facilitated by the organisation EdgyX. The second event will be a whole school day to integrate STEAM subjects. The students will be organised in multi-age groupings and will explore integrated activities relating to the theme.

**How did you start it?**

When the theme of 'Robots, Drones and Droids' was released, the teachers' problem solved ways to make it applicable to the age of the students in the school. We met with the P&F Executive and coordinator of the Secret Dad's Business and promoted the events in the newsletter. For the second event, we had regular meetings to plan ideas and then promoted this through our wider staff meetings.

**How long has it been running?**

Beginning in 2016.

**What year levels are involved?**

Kindergarten-year 4.

**Are you involved with other schools/groups/organisations?**

We are connected to 2 other organisations through this project:

1. The Fathering Project
2. EdgyX

**Do you have any advice for teachers who might like to run a similar program?**

Our biggest bit of advice would be to plan well in advance and to regularly communicate with various stakeholders.

**Useful contacts:**

EdgyX <http://www.edgyx.com.au>

Fathering Project <http://thefatheringproject.org>

### **Mentone Girls' Grammar (Vic.)**

**Teacher:** Helen Silvester.

**Name of program:** First Robots Competition.

#### **What is the aim of the program?**

Our aim is to build the knowledge and expertise of teachers and students in coding, engineering, teamwork and applied science through the First Robots competition. This competition requires students to build a full-sized robot and program it to fulfil set criteria. The 2016 competition requires the robot to cross barriers, open doors, shoot or push balls into holes and climb a tower. The robots will compete in teams in Sydney, however the competition is an international one with the option to compete overseas. There is a six week build time in January and February, where the students work with industry mentors to build and program their robot.

**Curriculum being addressed:** all areas of STEM

#### **Why did you start it?**

It has been a number of years since our school entered any similar competition. Natural movement of teaching staff resulted in a loss of expertise in these areas. Rather than recruit staff that specialised in solar cars, LEGO robots etc, it was decided to upskill students and staff over 2 years.

#### **How did you start it?**

In 2015, an all girls team (Robocats) was started by Milorad Cerovac in addition to his school team. The goal was to encourage girls to participate. Two girls from my school joined the team and brought their enthusiasm back to school. As a result, in 2016 students from different year levels were encouraged to join the Robocat team. This involved keeping students up to date with the build, acting as a mentor myself and facilitating transport where possible. I have also been making contact with past students and engineering and programming parents to make them aware of the program. Four students from my school will be travelling to Sydney for the competition.

In 2017 I hope to have 15 students involved and at least three past students/parents to act as mentors for the Robocats. This will give the mentors an idea of what is involved for when we launch our own team in 2018. There is a significant cost involved in this program and as a result I want to maximise the possibility of a competitive team. My involvement also allows me to source sponsorship for our school team.

**How long has it been running?** 1.5 years.

**What year levels are involved?** Years 8–12.

#### **What resources are needed and how did you access these resources?**

I have had significant help from an enthusiastic teacher, Milorad Cerovac, who is tireless in his support of not just the Robocats but many other teams around Victoria. I am contacting past students and parents to act as mentors and am currently sourcing sponsorship. The key is to involve as many teachers in the school as possible so the skills are not lost in the future.

#### **Are you involved with other schools/groups/organisations?**

Past students and parents with any experience in engineering and coding.

#### **How do you think the program is going so far?**

Enthusiasm is high and the Robocats are looking good for the competition

#### **Advice for teachers who might like to run a similar program.**

Don't be intimidated by the thought of setting up such a program. Take time and get the experience. Find other teachers/enthusiasts to keep the energy levels high. Don't expect to know everything yourself. Seek and accept help.

#### **Useful contacts :**

Past students and parents. Industry contacts through being involved in early set up years.

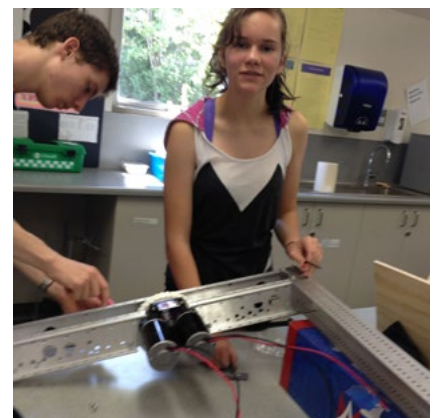

## Playford International College (SA)

### Teachers:

Sue Elderfield  
Head of STEM and i-SaM (Integrated Science & Mathematics)

Louise Minney  
Head of Global Studies (Humanities)  
Advanced Technologies Project School Manager

**Name of program:** STEM Academy.

### Curriculum being assessed:

Students are assessed against the relevant Australian Curriculum Achievement Standards in Design Technologies, Digital Technologies, Science and Mathematics for their year level. The specific standards therefore differ from student to student depending on the nature of their project and their year level. As an elective class, this assessment is in addition to what they already study in their core Science, Technology and Mathematics classes. In particular, we have found that students are often meeting the criteria found within the General Capabilities of Critical and Creative Thinking, Personal and Social, ICT, Numeracy and Ethical Understanding.

### What year levels are involved?

Years 8–10.

### How the program is run?

STEM Academy is an entirely team-taught, student directed Project Based Learning approach to teaching the engineering design process. In 2016, our program consists of 50 students from years 8, 9, and 10. Students form their own multi-year-level teams to design and create a product to solve an identified real-world problem. They select projects from a variety of fields involving remote control electronics, data logging, robotic programming (Arduino or EV3), computer coding, CAD, 3D printing and laser cutting. Students have the opportunity to enter local and national competitions such as the Australian STEM Video Game Challenge, Aurecon Bridge Building Competition, First LEGO League as well as several Concept 2 Creation (C2C) competitions involving RC Drones, Vehicles and Boats.

The class has a scheduled weekly double lesson two hours in length in which all 50 students are spread out between a few adjoining science laboratories. A typical lesson includes some brief direction from the teachers, from which students then assemble in their groups and work on designing and building their prototypes. Teachers move from group to group checking on progress, asking questions, and giving suggestions to assist students to overcome obstacles. We also invite engineers from local universities or companies with to visit our class to provide technical support to students as they grapple to operate advanced technologies.

Often the most powerful learning of students is how to delegate roles and responsibilities to team members, communicate effectively and keep project management records. Students are given scaffolds such as the Engineering Design Cycle and Project Management GANTT charts to help them organise resources and personnel to meet deadlines. These tools are included within regular interim reports and technical reports which are submitted as assessment tasks, however most assessment is conducted via scheduled formal conversations with teachers.

As a relatively new venture (standalone STEM classes have previously been operating for two years), we are in the process of creating a purpose-designed maker space. We intend to



fit out our classrooms with a laser cutter, 3D printers, woodworking benches with vices, soldering stations and laptops with high-end programming and design software such as Autodesk Inventor.

#### How is the program going so far?

We have a group of students working on the Concept 2 Creation SA Power Networks Drone challenge. To complete in this challenge, students need to design a detection and tracking system that could remotely identify faculty power cables and insulators at the top of electric supply towers. Currently they are deeply involved in learning to fly the drone.

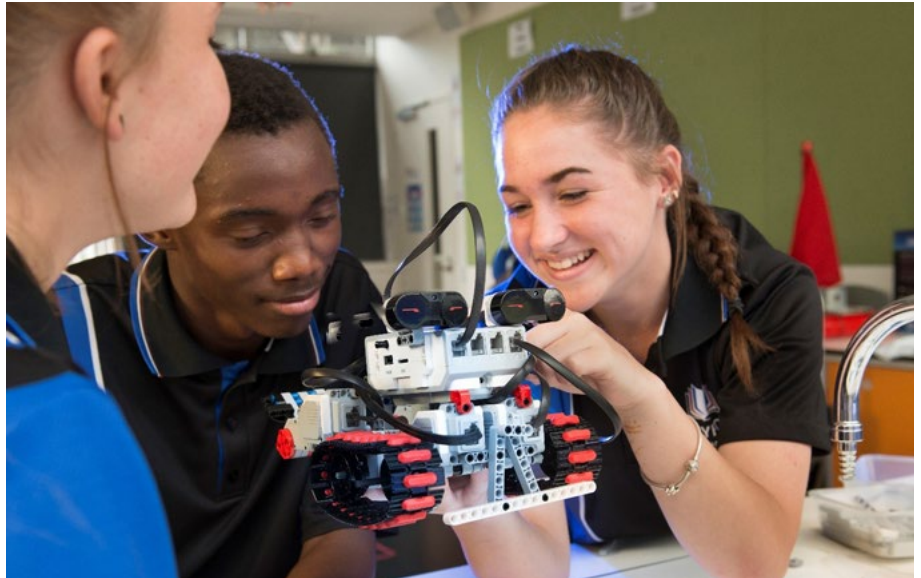

We have another group of students working on a Wetlands Environmental Challenge. Where they have to design, manufacture and build a remote controlled vehicle that will go out into a fresh water lake and collect and test water samples.

Our third group wants to build a walking robot. They have spent time learning how to build and program using an Arduino microcontroller and are currently working on programming a robot with wheels the next step is to research the electronic components required to replace the wheels with legs.

We also have a group designing a fish pond that has an above water viewing dome, a group solving the latest First LEGO League Challenge using EV3 robots, a group building bridges for the Aurecon Bridge Building Challenge, another group designing a cheap and portable water purifying system, a group building a solar powered phone charger and finally a group of students designing a video game for entrance into the Australian Video Game Challenge. All together we have 50 self-directed students, working in self defined groups on many different projects all with well-defined outcomes with links to real world problems.

## Quantum Victoria

**Quantum Victoria** is one of six specialist science and mathematics Centres established by the Victorian Department of Education and Training (DET) that builds the capacity of both students and teachers in the disciplines of Science, Technology, Engineering and Mathematics across Victoria and beyond through:

- Increasing students' interest, participation and engagement in science and mathematics and encouraging more students to pursue careers in the STEM disciplines.
- Expanding the knowledge base of teachers and building teacher capacity to engage students through our innovative programs underpinned by the latest research and pedagogy.

The blend of onsite and outreach programs embraces cutting edge, aspirational technologies and contemporary pedagogies with a particular focus on:

- 3D Printing and Modelling
- Games Technology



- Coding
- Robotics and Mechatronics
- Virtual reality and simulated experiences
- Gesture-Based Computing

Quantum Victoria provides access to all Victorian students with a focus on equity and a commitment to be at the forefront of emerging technologies.

The following schools are involved in programs run through Quantum:

School	Program
St Helena Secondary College	Quantum Forensic Investigation (QFI)
Roxburgh College	3D Printing and Modelling
Bundoora Secondary College	3D Printing and Modelling
Yarrowonga College	Quantum Forensic Investigation (QFI)
Koorie Secondary Initiative	Code Breakers
Ballarat Secondary College	Need for Speed
Charles La Trobe P-12 College	PrintACar Challenge Qualifying Day
Brighton Secondary College	PrintACar Challenge Qualifying Day
Christian College Geelong	PrintACar Challenge Qualifying Day
Essendon East Keilor College	PrintACar Challenge Qualifying Day
Lavalla Catholic College	PrintACar Challenge Qualifying Day
Christ the King Anglican College	PrintACar Challenge Qualifying Day
Woodside Primary School	PrintACar Challenge Qualifying Day
Lilydale High School	PrintACar Challenge Qualifying Day
Melbourne Girls College	PrintACar Challenge Qualifying Day
Bendigo South East 7-10 College	PrintACar Challenge Qualifying Day
Laburnum Primary School	PrintACar Challenge Qualifying Day
Numurkah Secondary College	PrintACar Challenge Qualifying Day
Scotch College	PrintACar Challenge Qualifying Day
Terang 5-12 College	Terang 5-12 College
Traralgon College	PrintACar Challenge Qualifying Day
William Ruthven Secondary College	PrintACar Challenge Qualifying Day
Creekside P-9 College	PrintACar Challenge Qualifying Day
St Leonards College	PrintACar Challenge Qualifying Day
Strathmore North Primary School	PrintACar Challenge Qualifying Day

#### What is the aim of the programs?

The programs encompass the disciplines of STEM and are aligned to the Australian Curriculum.

#### Curriculum being addressed:

STEM, Digital Technologies

**Why did you start it?**

The Centre's key goals are to build the capacity of F-12 students and teachers in the STEM disciplines. We aim to achieve this through our commitment to:

Excellence and Innovation	Through access to experts, cutting-edge, aspirational and emerging technologies, state of the art facilities and innovative pedagogical practices.
Equity	Access for all Victorian students regardless of gender, special needs, socio-economic or geographical location.
Engagement	Through innovative and contemporary programs defined by the latest research and pedagogy, incorporating inquiry, scenario, project-based learning and including the following aspirational technologies: 3D Printing and modelling, robotics and mechatronics, game-based learning, robotics and mechatronics, coding, gesture-based computing and virtual and simulated experiences.
Partnerships	For program enhancement and to build the capacity of the Centre staff, visiting students and teachers. These include: universities, scientific and research organisations and industry, resulting in robust STEM programs, statewide conferences, workshops and events.
Productivity and Resource Management	Through sound management of finances and resources aligned to the DET Funding Model and underpinned by the organizational values.

**How did you start it?**

The Centre was established by the DET. A team of teachers and experts that aligned with the goals and vision of Quantum Victoria to develop and deliver student and teacher programs under the STEM disciplines were recruited.

**How long has it been running?**

Quantum Victoria was established in April 2012.

**What year levels are involved?**

Years F-12.





**What resources are needed and how did you access these resources?**

The Centre has invested in IT/AV infrastructure to support all of our programs, including 3D printers, laptops, iPads, racing track, portable and fixed screens, theatre, wetlab, robots, CNC machine, Crestron system.

**Are you involved with other schools/groups/organisations?**

Partnership	Nature
La Trobe University	Engineering, robotics, UniBridges and pre-service teacher training through Reconceptualising Mathematics and Science Teacher Education (ReMSTEP).
University of Melbourne	3D Showcase and PrintACar Challenge, Carlton Connect, Science Gallery.
Engineers Australia	Statewide Engineering Expos in partnership with Victoria's Universities
Tall Poppies	Tall Poppy Events: Encouraging innovation and creativity through interactions between students and young researchers who have been recognized for their outstanding achievement in their area of expertise.
Science Teachers' Association of Victoria (STAV)	Hosting of and presenting at Teacher and Lab Tech Professional Learning statewide conferences and workshops.
Centre for All-Sky Astrophysics (CAASTRO)	Telescopes in Schools and student outreach program development
Specialist Science and Mathematics Centres Network in Victoria	BioLAB, EarthEd, Ecolinc, GTAC, and VSSEC, a network of high quality statewide educational resources driving improved science and mathematics education outcomes in Victoria, working collaboratively to achieve this goal.
In2science Peer Mentoring models in STEM disciplines.	Statewide events utilizing the expertise of university students as peer mentors and role
Questacon	Collaboration between teams and sharing expertise in game-based learning and 3D printing and modelling.
Square Kilometer Array Project (SKA)	Remote Virtual Lab, providing access to students and teachers throughout Victoria.
LEAP	Learn, Experience, Access Professionals: Statewide Engineering and Science Experiences.

**How do you think the program is going so far?**

The Centre has experienced an increased rate of student participation on average 14 per cent per annum, with 9,400 participating in our programs in 2015.

**Do you have any advice for teachers who might like to be involved?**

Immerse students in programs that illustrate the wonder and creativity of science and its applications in everyday life! Follow the links below to find out more on Quantum programs.

- the Quantum [website](#)
- social media: [Facebook](#) and [Twitter](#)
- program [flyers](#)
- Centre [brochure](#)

**Useful contacts:**

Quantum Victoria Director, Soula Bennett, [soula.bennett@quantumvictoria.vic.edu.au](mailto:soula.bennett@quantumvictoria.vic.edu.au)

Quantum Victoria Admin Officer, Anna Ziogas, [admin@quantumvictoria.vic.edu.au](mailto:admin@quantumvictoria.vic.edu.au)

## West End State School (Qld)

### Teachers:

Paula Thomas: Year 5 teacher.

David Jeffery: Enrichment teacher-aide.

Matt Tengdahl : Year 2 teacher.

Ruth Christie: Retired QUT Lecturer in Programming.

Ashleigh Smith: DET Learning Technologies, Web and Digital Delivery.

### Name of program:

STEAMakerspace Maxi years 4, 5 and 6.

STEAMakerspace Mini years 2 and 3.

### What is the aim of the program?

The aim is to create a space and provide opportunities to explore and tinker with selected resources which will foster curiosity and experimentation projects combining elements of Science, Technology, Engineering, Art and Mathematics.

### Curriculum being addressed:

Digital Technologies/ Design Technologies / Science/ Maths

### Why did you start it?

Many West End students were displaying interests in exploring electronics, coding, programming and engineering and the Australian Curriculum was extending into these directions. The idea of the STEAMakerspace was to dabble in all of these areas in a sandpit environment and investigate a variety of resources and explore the potential of these different technologies and their links to the Australian Curriculum.

### How did you start it?

Paula Thomas started in her own class and planned the provision of experimental opportunities using Drones and iPads and construction materials. It started as a Genius Hour similar to Google 20% program where students could explore any area of interest in Digital Technologies. They dismantled computers, created a replica of the school in Minecraft and created their own doll's clothes store and researched black holes.

### How long has the program been running?

12 months.

### What year levels are involved?

Initially the program was offered to year 5 but now it has been extended to years 4, 5 and 6.

The STEAMakerspace Mini was started this year to cater for interested year 3 students and will be extended to year 2.

### How is the program run?

The STEAMakerspace is run on Thursdays during lunch breaks and there are places for 24 students.

Students apply for a place by completing an open-ended design brief. "If you could make an invention that would **Change The World** and make it a better place what would it be? Describe what you would make and how it would work. Draw a diagram

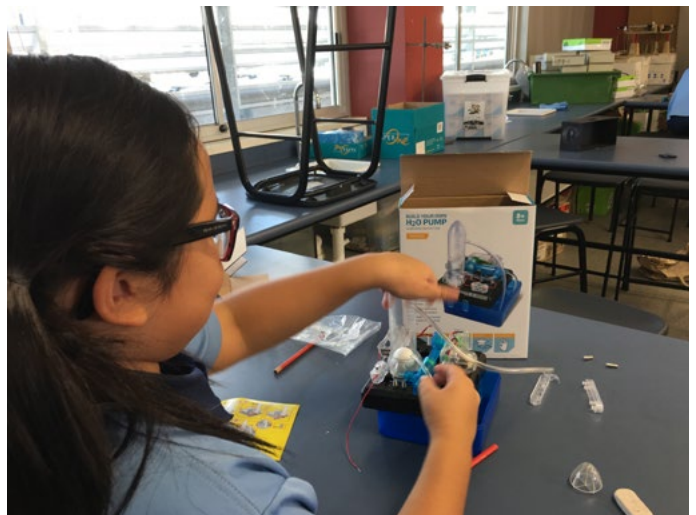

of your invention to show how you would build it. Label your diagram with all the different features and what they do. What materials would you use to make this invention and why would you use them?"

The students are free to use any of the resources and choose to work on one project for a few weeks or change each week. This is a constantly evolving process and is driven by student direction with the teachers supplying a selection of ideas which are optional.

#### **What resources are needed and how did you access these resources?**

Initial resources for Semester 2, 2015 were bought with school funds for extracurricular activities.

Initially, the Principal Judy Thompson bought Parrot Drones, Dot and Dash Robots, Little Bits, Makey Makeys, Arduino kits, a selection of all-purpose Electronic Kits from Aldi, and individual kits such as Bubble Making machines, Electric Fans and Battery Testers etc. Five iPads are available for visual programming of Drones and Robots using Tickle, Xylo, Blockly and Edware.

West End State School Student Council donated funds for the 2016 STEAMakerspace and selected the types of resources they wanted purchased with the funds. These were a set of Edison Robots, extra sets of Little Bits, Makedo Kits, iPad tripod attachments for filming, supplies of large tape dispensers, jumbo marking pens and other construction materials.

Purpose built lockable cupboards allow all the resources to be organised and stored securely.

#### **Are you involved with other schools/groups/organisations?**

Paula Thomas is involved with the Apple Distinguished Educator Group, Ed Qld Coding Discussion Group, Dream Factory EdStudio and G20 Group for sharing of ideas.

Ruth Christie from QUT works as a volunteer and also as a mentor for students and teachers in programming. In her spare time she researches problems in programming robots.

Ashleigh Smith is the Acting Principal Project Officer for the Dream factory.

#### **How do you think the program is going so far?**

The students are full of enthusiasm, bound with so much energy and are heading off at a variety of tangents and don't want to pack up. They email Paula Thomas with ideas day and night and there just isn't enough time to explore and complete projects within the lunch time limit of 45 minutes. Each week is unpredictable and the atmosphere is chaotic but creative. The cohort are due to change in a few weeks to provide opportunities for new students and I am not sure the original group have had enough opportunities to explore their potential.

The Edison Robots have now flowed into the classroom in a year 5 Digital Technologies Curriculum for an eight-week unit. This could be a direction to follow for other year levels in the future.

#### **What advice do you have for teachers who might like to run a similar program?**

- Start small with a few carefully selected open-ended resources. Select some involving construction, electronics, visual programming and robotics.
- Design an application form that will allow highly motivated and creative students to shine.
- Organise a strict charging routine and purchase additional batteries for drones and robots.
- Trial resources with your own class.
- Gather together a team with a wide variety of skills.
- Be prepared for a chaotic ride.

#### **Useful contacts:**

[Little Bird Electronics](#) for supplies

[AHS Makerspace Blog](#) MeetEdison.com

'Little Bits' Newsletter

Amazon for cheaper supplier of robots



## Science Program Exciting Children Through Research Activities

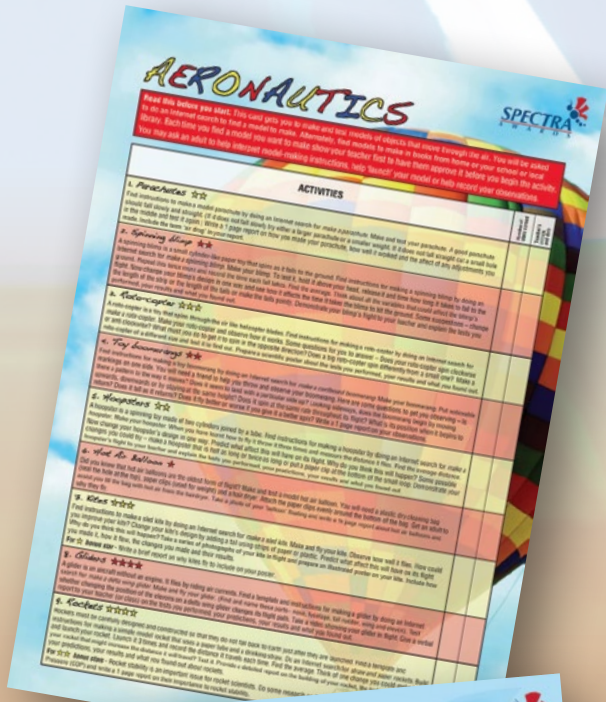

### SPECTRA:

- inspires students
- develops investigative skills
- encourages student initiative
- provides a tangible, collectable reward
- minimises teacher workload

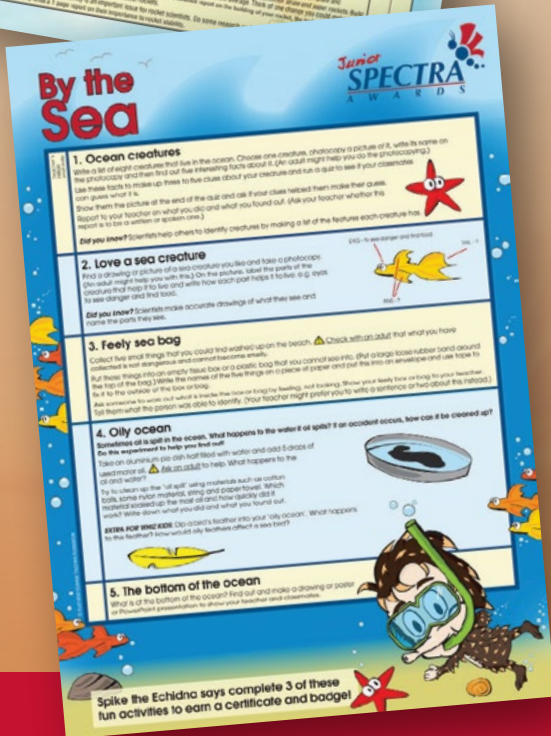

For more details: